

**TN POLYTECHNIC – REGULATION  
2023**

**DIPLOMA IN ENGINEERING &  
TECHNOLOGY**

**SECOND SEMESTER SYLLABI**

**DIPLOMA IN ENGINEERING & TECHNOLOGY**  
**NEW REGULATION - 2023**  
**SECOND SEMESTER FINAL SYLLABI**

<b>S.No</b>	<b>SUBJECTS</b>	<b>SUBJECT CODE</b>
1	APPLIED MATHEMATICS - I (Non-Circuit)	MA232431
2	APPLIED MATHEMATICS – II (Circuit)	MA232432
3	APPLIED PHYSICS -I (Non-Circuit)	PH232441
4	APPLIED PHYSICS -II (Circuit)	PH232442
5	APPLIED CHEMISTRY (Non-Circuit)	CH232451
6	APPLIED CHEMISTRY (Circuit)	CH232452
7	COMMUNICATIVE ENGLISH -II	EN232480
8	BASICS OF MECHANICAL ENGINEERING	ME232120
9	BASICS OF CIVIL ENGINEERING	CE232120
10	BASICS OF ELECTRICAL AND ELECTRONICS ENGINEERING	EE232120
11	BASICS OF COMPUTER ENGINEERING	CS232120
12	DRAFTING PRACTICES	DP232270
13	BASIC ENGINEERING PRACTICES	EP232460

<b>MA232431</b>	<b>APPLIED MATHEMATICS – I [Non-circuit Branches]</b>	L	T	P	C
<b>Practicum</b>		1	0	4	3

### **Introduction**

The knowledge of Mathematics is necessary for a better understanding of all engineering and science subjects. Computer based visual representations such as graphs, animations, and tables of Mathematical ideas will enhance the applicability of Mathematics in engineering domains. This course is designed to give a comprehensive coverage at an introductory level to the topics of Coordinate Geometry, Differential Calculus, Integral Calculus and Statistical Process Control and some of their applications to engineering domains.

### **Course Objectives**

The objective of this course is to enable the students to

- Summarize the properties of families of circles.
- Identify the type of conic represented by a general second-degree equation in two variables.
- Acquire knowledge in the principles of differentiation.
- Summarize the methods of integration and their engineering applications.
- Identify the statistical tools required for the quality control of manufacturing processes.

### **Course Outcomes**

After successful completion of this course, the students should be able to

CO1: Determine whether two circles with given equations touch internally or externally.

CO2: Compute the vertex, focus, directrix and latus-rectum of parabola and ellipse.

CO3: Calculate limits and derivatives of one variable functions.

CO4: Evaluate definite integrals and indefinite integrals.

CO5: Determine the out-of-control signals in manufacturing processes.

### **Pre-requisites**

High School Mathematics

## CO/PO Mapping

CO / PO	P01	P02	P03	P04	P05	P06	P07
C01	3	3	2	1	1	1	3
C02	3	3	2	1	1	1	3
C03	3	3	2	1	1	1	3
C04	3	3	2	1	1	1	3
C05	3	3	2	1	1	1	3

Legend: 3-High Correlation, 2-Medium Correlation, 1-Low Correlation

## Instructional Strategy

- Use explicit instruction for developing Math vocabulary and conceptual understanding.
- Use inducto-deductive approach to achieve the desired learning objectives.
- Use open-ended questions to nurture the problem-solving and reasoning skills among students.
- A theory-demonstrate-practice-activity strategy may be used throughout the course to ensure that learning is outcome-based and employability-based.
- Encourage students through illustrated problems and hand-on activities to use visual methods and simulations to solve real problems.

## Assessment Methodology

	Continuous Assessment (40 marks)				End Semester Examination (60 marks)
	CA1	CA2	CA3	CA4	
Mode	Lab Test (Ex-1 to 4)	Written Test (Units-I to III)	Lab Test (Ex-5 to 10)	Record (Ex-1 to 10)	Practicum Exam
Duration	2 hours	2 hours	2 hours		3 hours
Exam Marks	70	30	70	100	100 (Theory:30+Practical:70)
Converted to	10	10	10	10	60
Marks	40				60

### Note:

- 1) One practical exercise question shall be given for each CA1 and CA3. The mark allocation is Aim: 10 marks, Procedure: 20 marks, Output: 30 marks, Viva-voce: 10 marks.

- 2) 20 questions shall be given from the theory portion for CA2, out of which 15 have to be answered. Each question carries 2 marks.
- 3) Each experiment should be evaluated for 10 marks in CA4.

MA232431	APPLIED MATHEMATICS – I [Non-circuit Branches]				L	T	P	C
Practicum					1	0	4	3
Unit I	COORDINATE GEOMETRY – 1							
<p><b>THEORY</b> Equation of a circle with given centre and radius – General equation of circles – Centre and radius of a circle from general equation – Concentric circles – Contact of circles – Orthogonal circles – Simple problems.</p>								3
<p><b>PRACTICAL</b> Basics of GeoGebra (Not for examinations)</p> <ol style="list-style-type: none"> <li>i. Familiarize the interfaces of GeoGebra such as Graphics View, Algebra View, Graphics2, Spreadsheet, Computer Algebra System (CAS), Probability Calculator and 3D Graphics.</li> <li>ii. Familiarize the Tool Bar and important tools of GeoGebra.</li> </ol> <p>Ex-1: For the given equations of the circles <math>x^2 + y^2 + 2g_1x + 2f_1y + c_1 = 0</math> and <math>x^2 + y^2 + 2g_2x + 2f_2y + c_2 = 0</math> with appropriate coefficients,</p> <ol style="list-style-type: none"> <li>i. Graph the equations of the circles in the Cartesian plane.</li> <li>ii. Determine the coordinates of the centres and radii of the circles and mark them on the graph.</li> <li>iii. Determine the distance between the centres of the circles.</li> <li>iv. Determine whether the circles are touching each other or not.</li> <li>v. If the circles are touching each other, determine whether they are touching internally or externally.</li> <li>vi. Verify whether any of the relationships <math>C_1C_2 = r_1 + r_2</math> or <math>C_1C_2 =  r_1 - r_2 </math> holds or not.</li> </ol>								5
<p>Ex-2: A pair of spur gears consists of (<math>z_p =</math>) 20 teeth pinion meshing with (<math>z_g =</math>) 120 teeth gear. Let the module be (<math>m =</math>) 4 mm.</p> <ol style="list-style-type: none"> <li>i. Calculate the pitch circle diameters of the pinion and the gear using the formulae <math>d_p = mz_p</math> and <math>d_g = mz_g</math>.</li> <li>ii. Calculate the distance between the centres of the pinion and the gear using the formula <math>\frac{1}{2}(d_p + d_g)</math>.</li> <li>iii. Draw two externally touching circles to represent pinion and gear with appropriate centres and radii <math>\frac{1}{2}d_p</math> and <math>\frac{1}{2}d_g</math>. Determine the equations of the pinion and gear. Calculate the distance between the centres of the circles from the graph and verify that it is equal to <math>\frac{1}{2}(d_p + d_g)</math>.</li> <li>iv. Calculate the tooth thickness using the formula <math>t = 1.5708m</math>.</li> <li>v. Calculate the gear ratio using the formula <math>i = \frac{z_g}{z_p}</math>.</li> </ol>								6

Note: Appropriate values for $z_p, z_g, (z_g > z_p)$ and $m$ can be assigned by the course teacher/examiner in Ex-2.		
<b>Unit II</b>	<b>COORDINATE GEOMETRY – 2</b>	
<p><b>THEORY</b>  General equation of conics – Classification of conics – Standard equations of parabola – Vertex, focus, axis, directrix, focal distance, focal chord, latus-rectum of parabola – Standard equations of ellipse – Vertices, foci, major axis, minor axis, directrices, eccentricity, centre and latus-rectums of ellipse – Simple problems.</p>		3
<p><b>PRACTICAL</b>  Ex-3:  Do the following activities.</p> <p>(i) Draw the graphs of the parabolas <math>(y - k)^2 = 4a(x - h)</math> and <math>(x - h)^2 = 4a(y - k)</math> for the given values of <math>a, b, h</math> and <math>k</math>. Determine the vertex, focus, axis, directrix, latus-rectum of each parabola and mark them on the graphs.</p> <p>(ii) Draw the graphs of the ellipse <math>\frac{(x-h)^2}{a^2} + \frac{(y-k)^2}{b^2} = 1</math> for the given values of <math>a, b, h</math> and <math>k</math>. Determine the eccentricity, centre, foci, vertices, major axis, minor axis, directrices, and latus-rectums and mark them on the graph.</p> <p>Ex-4:  Do the following activities for the given image of a parabolic shaped fly-over bridge.</p> <p>(i) Draw a parabola which fits the given bridge.  (ii) Write the equation of the parabola.  (iii) Find the vertex, focus, directrix and latus-rectum and mark them on the graph.  (iv) Find the height and width of the bridge.</p>		5
		6
<b>Unit III</b>	<b>DIFFERENTIAL CALCULUS</b>	
<p><b>THEORY</b>  Limits of polynomials and rational functions – Limits of the form <math>\lim_{x \rightarrow 0} \frac{\sin ax}{bx}</math> and <math>\lim_{x \rightarrow 0} \frac{\tan ax}{bx}</math> (<math>x</math> in radians) (results only) – Definition of differentiability – Differentiation formulae for standard functions – Differentiation of sum, difference, product and quotient of functions – Chain rule – Second order derivatives – Radius of curvature – Simple problems.</p>		3
<p><b>PRACTICAL</b>  Ex-5:  Do the following activities.</p> <p>(i) Graph the polynomial function <math>f(x) = a_n x^n + a_{n-1} x^{n-1} + \dots + a_1 x + a_0</math>, where <math>a_n, a_{n-1}, \dots, a_0</math> are real numbers and <math>a_n \neq 0</math>. Find the value of <math>f(x)</math> at <math>x = a</math> and the limit of <math>f(x)</math> at <math>x = a</math>.</p> <p>(ii) Graph the rational function <math>R(x) = \frac{a_n x^n + a_{n-1} x^{n-1} + \dots + a_1 x + a_0}{b_m x^m + b_{m-1} x^{m-1} + \dots + b_1 x + b_0}</math>, where <math>a_n, a_{n-1}, \dots, a_0, b_m, b_{m-1}, \dots, b_0</math> are real numbers and <math>a_n, b_m \neq 0</math>. Find the value of <math>f(x)</math> and the limit of <math>f(x)</math> at <math>x = a</math>.</p> <p>(iii) Graph the functions <math>\frac{\sin ax}{bx}</math> and <math>\frac{\tan ax}{bx}</math> where <math>a</math> and <math>b</math> are real numbers and <math>a, b \neq 0</math>.  Evaluate <math>\lim_{x \rightarrow 0} \frac{\sin ax}{bx}</math> and <math>\lim_{x \rightarrow 0} \frac{\tan ax}{bx}</math>.</p> <p>(iv) Graph the functions <math>c</math> (constant), <math>x^n</math>, <math>\sin x</math>, <math>\cos x</math>, <math>\tan x</math>, <math>\operatorname{cosec} x</math>, <math>\sec x</math>, <math>\cot x</math>, <math>e^x</math> and</p>		5

	<p><math>\log x</math>. Find their first derivative and second derivative.  Note: Only two functions will be given in Board Practical Examination in subdivision-(iv) of Ex-5.</p> <p>Ex-6:  Two parallel straight lines of 'x' m apart are to be connected by a reverse curve consisting of arcs of same radius. The distance between the end points of the curve is 'y' m.  (i) Find the approximate value of the common radius.  (ii) Find the length of the whole curve.</p>	6
<b>Unit IV</b>	<b>INTEGRAL CALCULUS</b>	
	<p><b>THEORY</b>  Integration formulae of standard functions as inverse operation of differentiation – Bernoulli's formula – Definite integrals (Properties are excluded) – Area and volume using integration – Simple problems.</p>	3
	<p><b>PRACTICAL</b>  Ex-7:  Do the following activities.  i. Graph the functions <math>c</math> (constant), <math>x^n, n \in \mathbb{R}, e^x, \sin x, \cos x, \sec^2 x, \operatorname{cosec}^2 x, \sec x \tan x</math> and <math>\operatorname{cosec} x \cot x</math>. Find their indefinite integrals.  ii. Evaluate the definite integral <math>\int_a^b f(x) dx</math> and relate it to the area under the curve <math>y = f(x)</math> between <math>x</math>-axis, <math>x = a</math> and <math>x = b</math>.  iii. Find the volume of the solid generated by the revolution of the area bounded by <math>y = f(x), x</math>-axis, <math>x = a</math> and <math>x = b</math> about <math>x</math>-axis.  Note: Only two functions will be given in Board Practical Examination in subdivision-(i) of Ex-7.</p> <p>Ex-8:  Do the following activities for the given image of a closed irregular plane figure.  i. Mark the required number of points on the boundary of the figure.  ii. Draw the boundary of the figure by joining the points.  iii. Divide the figure into trapeziums using the points on the boundary.  iv. Calculate the approximate area of the figure.</p>	5
<b>Unit V</b>	<b>STATISTICAL PROCESS CONTROL</b>	
	<p><b>THEORY</b>  Random variables – Continuous random variables – Normal distribution – Process average and process variation using arithmetic mean and variance – Central line (CL), upper control limit (UCL) and lower control limit (LCL) – Control charts – <math>\bar{X}</math> charts – Out-of-control signals – Simple problems.</p>	3
	<p><b>PRACTICAL</b>  Ex-9:  Do the following activities.  i. Find the mean <math>\mu</math> for the given data <math>x_1, x_2, x_3, \dots, x_{50}</math> of size <math>N = 50</math>.  ii. Find the variance <math>\sigma^2</math> and standard deviation <math>\sigma</math> for the data given in (i).  iii. Fit the normal curve <math>f(x) = N(\mu, \sigma^2) = \frac{1}{\sigma\sqrt{2\pi}} e^{-\frac{1}{2}\left(\frac{x-\mu}{\sigma}\right)^2}, -\infty &lt; x &lt; \infty</math>.</p>	5

- iv. Calculate the probability  $p = P(X_1 < X < X_2)$  for some  $X_1, X_2$  in the range of the data given in (i) using the formula  $\int_{X_1}^{X_2} f(x)dx$ . Verify the answer using probability calculator.
- v. Calculate the number of data points in the interval  $(X_1, X_2)$  using the formula  $n = Np$ .

Ex-10:

Consider the 4 samples each of size 5 taken from the production lot of a machine.

Sample Number	$S_{i1}$	$S_{i2}$	$S_{i3}$	$S_{i4}$	$S_{i5}$
$S_1$	$x_{11}$	$x_{12}$	$x_{13}$	$x_{14}$	$x_{15}$
$S_2$	$x_{21}$	$x_{22}$	$x_{23}$	$x_{24}$	$x_{25}$
$S_3$	$x_{31}$	$x_{32}$	$x_{33}$	$x_{34}$	$x_{35}$
$S_4$	$x_{41}$	$x_{42}$	$x_{43}$	$x_{44}$	$x_{45}$

- i. Calculate the sample means  $\bar{S}_1, \bar{S}_2, \bar{S}_3, \bar{S}_4$  and the mean of the sample means  $\bar{\bar{S}} = \frac{\bar{S}_1 + \bar{S}_2 + \bar{S}_3 + \bar{S}_4}{4}$ .
- ii. Calculate the sample variances  $v_1, v_2, v_3, v_4$  and  $\sigma = \sqrt{\frac{1}{4} \sum_{i=1}^4 v_i}$ .
- iii. Determine the central line  $CL = \bar{\bar{S}}$ , lower control limit  $LCL = \bar{\bar{S}} - \frac{2.58}{\sqrt{5}} \sigma$  and upper control limit  $UCL = \bar{\bar{S}} + \frac{2.58}{\sqrt{5}} \sigma$ .
- iv. Draw the  $\bar{X}$  chart and determine the out-of-control signals.

6

**TOTAL HOURS**

**75**

**Note:** While setting up the practical exercise questions, the course teacher/examiner shall assign appropriate functions/constants wherever they are not mentioned explicitly.

### Suggested List of Students Activities

Other than classroom learning, the following are the suggested student related co-curricular activities which can be undertaken to accelerate the attainment of the various outcomes in this course.

- Explore the working principle of gear wheels in laboratory.
- Find the equation of a parabolic bridge using GeoGebra simulation
- Find the radius of curvature of an image of a train road.
- Find the volume of a water bottle using GeoGebra simulation of the image of the bottle.
- Collect samples from an industry and draw  $\bar{X}$  chart for the data.



## References

1. Higher Secondary First Year Mathematics Volume-I & Volume-II, Tamil Nadu Textbook and Educational Services Corporation, Government of Tamil Nadu, 2022.
2. Higher Secondary Second Year Mathematics Volume-I & Volume-II, Tamil Nadu Textbook and Educational Services Corporation, Government of Tamil Nadu, 2022.
3. John Bird, Higher Engineering Mathematics, Newnes (Elsevier), 6<sup>th</sup> Edition, 2010.
4. Grewal, B.S., Higher Engineering Mathematics, Khanna Publishers, 42<sup>nd</sup> Edition, 2012.
5. Deepak Singh, Mathematics-I, Khanna Book Publishing Co. (P) Ltd., 2021.
6. Garima Singh, Mathematics-II, Khanna Book Publishing Co. (P) Ltd., 2021.
7. John Vince, Calculus for Computer Graphics, Second Edition, Springer, 2019.
8. GeoGebra Manual, The Official Manual of GeoGebra (PDF Version), 2016.
9. GeoGebra Handbook for Senior Secondary Mathematics Teachers, Regional Institute of Education, Mysuru, 2016.
10. Steve Phelps, An Introduction to GeoGebra, GeoGebra Institute of Ohio, University of Cincinnati.

## Web-based/Online Resources

1. <https://www.khanacademy.org/math/>
2. <https://www.mathportal.org/>
3. <https://openstax.org/subjects/math>
4. <https://www.mathhelp.com/>
5. <https://www.geogebra.org/>
6. <https://www.desmos.com/>
7. <https://phet.colorado.edu/>

## Hardware Requirement

- Desktop Computers: 30 + 2 Nos.
- Projector and Screen
- Printer

## Software Requirement

- Operating System: Windows 7 or later
- GeoGebra Classic 5 (Free version)

## Allocation of Marks for End Semester Exam

<b>Part</b>	<b>Description</b>	<b>Marks</b>
A	Written Test (Theory Portion)	30
B	Aim	10
C	Procedure	20
D	Output	30
E	Viva-voce	10
<b>Total</b>		<b>100</b>

**Note:**

- 1) 20 questions shall be given from the theory portion, out of which 15 have to be answered. Each question carries 2 marks.
- 2) One practical exercise question shall be given for practical exam.

<b>MA232432</b>	<b>APPLIED MATHEMATICS – II [Circuit Branches]</b>	L	T	P	C
<b>Practicum</b>		1	0	4	3

### **Introduction**

The knowledge of Mathematics is necessary for a better understanding of all engineering and science subjects. Computer based visual representations such as graphs, animations, and tables of Mathematical ideas will enhance the applicability of Mathematics in engineering domains. This course is designed to give a comprehensive coverage at an introductory level to the topics of Coordinate Geometry, Trigonometry, Complex Numbers, Differential Calculus and Integral Calculus and some of their applications to engineering domains.

### **Course Objectives**

The objective of this course is to enable the students to

- Identify the type of conic represented by a general second-degree equation in two variables.
- Understand the properties of inverse trigonometric functions.
- Identify the applications of complex numbers in solving engineering problems.
- Acquire knowledge in the principles of differentiation.
- Summarize the methods of integration and their engineering applications.

### **Course Outcomes**

After successful completion of this course, the students should be able to

- CO1: Compute the vertex, focus, directrix and latus-rectum of parabola and ellipse.  
CO2: Solve problems using the properties of inverse trigonometric functions.  
CO3: Solve problems using arithmetic operations on complex numbers.  
CO4: Calculate limits and derivatives of one variable functions.  
CO5: Evaluate definite integrals and indefinite integrals.

### **Pre-requisites**

High School Mathematics

## CO/PO Mapping

CO / PO	P01	P02	P03	P04	P05	P06	P07
C01	3	3	2	1	1	1	3
C02	3	3	2	1	1	1	3
C03	3	3	2	1	1	1	3
C04	3	3	2	1	1	1	3
C05	3	3	2	1	1	1	3

Legend: 3-High Correlation, 2-Medium Correlation, 1-Low Correlation

## Instructional Strategy

- Use explicit instruction for developing Math vocabulary and conceptual understanding.
- Use inducto-deductive approach to achieve the desired learning objectives.
- Use open-ended questions to nurture the problem-solving and reasoning skills among students.
- A theory-demonstrate-practice-activity strategy may be used throughout the course to ensure that learning is outcome-based and employability-based.
- Encourage students through illustrated problems and hand-on activities to use visual methods and simulations to solve real problems.

## Assessment Methodology

	Continuous Assessment (40 marks)				End Semester Examination (60 marks)
	CA1	CA2	CA3	CA4	
Mode	Lab Test (Ex-1 to 4)	Written Test (Units-I to III)	Lab Test (Ex-5 to 10)	Record (Ex-1 to 10)	Practicum Exam
Duration	2 hours	2 hours	2 hours		3 hours
Exam Marks	70	30	70	100	100 (Theory:30+Practical:70)
Converted to	10	10	10	10	60
Marks	40				60

### Note:

- 1) One practical exercise question shall be given for each CA1 and CA3. The mark allocation is Aim: 10 marks, Procedure: 20 marks, Output: 30 marks, Viva-voce: 10 marks.

- 2) 20 questions shall be given from the theory portion for CA2, out of which 15 have to be answered. Each question carries 2 marks.
- 3) Each experiment should be evaluated for 10 marks in CA4.

MA232432		APPLIED MATHEMATICS –II [Circuit Branches]			
Practicum		L	T	P	C
		1	0	4	3
Unit I	COORDINATE GEOMETRY				
THEORY General equation of conics – Classification of conics – Standard equations of parabola – Vertex, focus, axis, directrix, focal distance, focal chord, latus-rectum of parabola – Standard equations of ellipse – Vertices, foci, major axis, minor axis, directrices, eccentricity, centre and latus-rectums of ellipse – Simple problems.					3
PRACTICAL Basics of GeoGebra (Not for examinations) <ol style="list-style-type: none"> <li>Familiarize the interfaces of GeoGebra such as Graphics View, Algebra View, Graphics2, Spreadsheet, Computer Algebra System (CAS), Probability Calculator and 3D Graphics.</li> <li>Familiarize the Tool Bar and important tools of GeoGebra.</li> </ol> Ex-1: Do the following activities. <ol style="list-style-type: none"> <li>Draw the graphs of the parabolas <math>(y - k)^2 = 4a(x - h)</math> and <math>(x - h)^2 = 4a(y - k)</math> for the given values of <math>a, b, h</math> and <math>k</math>. Determine the vertex, focus, axis, directrix, latus-rectum of each parabola and mark them on the graphs.</li> <li>Draw the graphs of the ellipse <math>\frac{(x-h)^2}{a^2} + \frac{(y-k)^2}{b^2} = 1</math> for the given values of <math>a, b, h</math> and <math>k</math>. Determine the eccentricity, centre, foci, vertices, major axis, minor axis, directrices, and latus-rectums and mark them on the graph.</li> </ol> Ex-2: Do the following activities for the given image of a parabolic shaped satellite dish antenna. <ol style="list-style-type: none"> <li>Draw a parabola which fits the given image of the dish antenna.</li> <li>Write the equation of the parabola.</li> <li>Find the vertex, focus, directrix and latus-rectum and mark them on the graph.</li> <li>How far from the vertex should the receiver of the antenna be placed?</li> </ol>					5
					5
					6
Unit II	INVERSE TRIGONOMETRIC FUNCTIONS				
THEORY Recapitulation of domain and range of $\sin x, \cos x, \tan x, \operatorname{cosec} x, \sec x$ and $\cot x$ and their graphs – Definition of inverse trigonometric functions – Domain and range of $\sin^{-1} x, \cos^{-1} x, \tan^{-1} x, \operatorname{cosec}^{-1} x, \sec^{-1} x, \cot^{-1} x$ and their graphs – Principle values of inverse trigonometric functions – Simple problems.					3

<p>PRACTICAL</p> <p>Ex-3: Do the following activities.</p> <ol style="list-style-type: none"> <li>Draw the graphs of <math>\sin x, \cos x, \tan x, \operatorname{cosec} x, \sec x</math> and <math>\cot x</math> and write their domain and range. Find the maximum value, minimum value, amplitude and periodicity of <math>\sin x, \cos x, \tan x, \operatorname{cosec} x, \sec x</math> and <math>\cot x</math>.</li> <li>Draw the graphs of <math>\sin^{-1} x, \cos^{-1} x, \tan^{-1} x, \operatorname{cosec}^{-1} x, \sec^{-1} x</math> and <math>\cot^{-1} x</math> and write their domain and range. Find the maximum value and minimum value of <math>\sin^{-1} x, \cos^{-1} x, \tan^{-1} x, \operatorname{cosec}^{-1} x, \sec^{-1} x</math> and <math>\cot^{-1} x</math>.</li> </ol> <p>Note: Only two functions will be given in Board Practical Examination in all subdivisions of Ex-3.</p> <p>Ex-4: The alternating current passing through a circuit is <math>i(t) = I_m \sin \omega t</math>, where <math>I_m</math> is the maximum value of current and <math>\omega</math> is the angular velocity. Let <math>R</math> be the resistance and <math>V_m</math> be the maximum voltage.</p> <ol style="list-style-type: none"> <li>Graph the sinusoidal waveform of <math>i(t)</math> for the given values of <math>I_m</math> and <math>\omega</math>.</li> <li>Calculate the maximum voltage <math>V_m</math> using the formula <math>V_m = I_m R</math> for the given value of <math>R</math>.</li> <li>Graph the sinusoidal waveform of voltage using the formula <math>v(t) = V_m \sin \left( \omega t + \frac{\pi}{2} \right)</math>.</li> <li>Determine the value of root mean square (r.m.s) current.</li> <li>Determine the frequency.</li> <li>Calculate the instantaneous value of the current at <math>t</math> sec.</li> </ol>		<p>5</p> <p>6</p>
<p><b>Unit III      COMPLEX NUMBERS</b></p>		
<p>THEORY</p> <p>Definition of a complex number – Real and imaginary parts – Modulus and argument – Polar form of a complex number – Conjugate of a complex number – Representation of complex numbers on Argand plane – Addition, subtraction, multiplication and division of complex numbers – De-Moivre’s theorem (without proof) - Simple problems.</p>	<p>3</p>	

<p>PRACTICAL</p> <p>Ex-5:</p> <p>Do the following activities.</p> <ol style="list-style-type: none"> <li>Mark the given complex number <math>z</math> on the Argand plane. Find the real and imaginary parts of <math>z</math>. Find the distance of <math>z</math> from <math>x</math>-axis and relate it to the real part of <math>z</math>. Find the distance of <math>z</math> from <math>y</math>-axis and relate it to the imaginary part of <math>z</math>.</li> <li>Find the conjugate of <math>z</math>. Mark <math>\bar{z}</math> on the Argand plane. Find the reflection of <math>z</math> on <math>x</math>-axis and relate it to <math>\bar{z}</math>.</li> <li>Find the modulus of <math>z</math>. Find the distance between <math>z</math> and origin of the Argand plane and relate it to the modulus of <math>z</math>. Find the modulus of <math>\bar{z}</math> and relate it to the modulus of <math>z</math>.</li> <li>Find the argument of <math>z</math>. Find the angle between the line segment <math>Oz</math> and <math>x</math> axis and relate it to the argument of <math>z</math>. Find the argument of <math>\bar{z}</math> and relate it to the argument of <math>z</math>.</li> </ol> <p>Ex-6:</p> <p>Do the following activities.</p> <ol style="list-style-type: none"> <li>The representation of apparent power as phasor sum of active power and reactive power is given by <math>S = 550 + 952.63j</math>. Draw the phasor diagram of the system. Find the numerical value of the apparent power. Also calculate the phase angle and power factor of the system.</li> <li>A machine takes 10KW (real power, <math>P</math>) at a power factor of 0.6 from 400V supply. Calculate the total load in KVA and KVAR. Represent the apparent power as a phasor sum of active power and reactive power.</li> </ol> <p>Note: The course teacher/examiner can assign appropriate values for <math>S, P</math>, power factor and supply in Ex-6.</p>	5
<b>Unit IV      DIFFERENTIAL CALCULUS</b>	
<p>THEORY</p> <p>Limits of polynomials and rational functions – Limits of the form <math>\lim_{x \rightarrow 0} \frac{\sin ax}{bx}</math> and <math>\lim_{x \rightarrow 0} \frac{\tan ax}{bx}</math> (<math>x</math> in radians) (results only) – Definition of differentiability – Differentiation formulae for standard functions – Differentiation of sum, difference, product and quotient of functions – Chain rule – Second order derivatives – Maxima and minima – Simple problems.</p>	3
<p>PRACTICAL</p> <p>Ex-7:</p> <p>Do the following activities.</p> <ol style="list-style-type: none"> <li>Graph the polynomial function <math>f(x) = a_n x^n + a_{n-1} x^{n-1} + \dots + a_1 x + a_0</math>, where <math>a_n, a_{n-1}, \dots, a_0</math> are real numbers and <math>a_n \neq 0</math>. Find the value of <math>f(x)</math> at <math>x = a</math> and the limit of <math>f(x)</math> at <math>x = a</math>.</li> <li>Graph the rational function <math>R(x) = \frac{a_n x^n + a_{n-1} x^{n-1} + \dots + a_1 x + a_0}{b_m x^m + b_{m-1} x^{m-1} + \dots + b_1 x + b_0}</math>, where <math>a_n, a_{n-1}, \dots, a_0, b_m, b_{m-1}, \dots, b_0</math> are real numbers and <math>a_n, b_m \neq 0</math>. Find the value of <math>f(x)</math> and the limit of <math>f(x)</math> at <math>x = a</math>.</li> <li>Graph the functions <math>\frac{\sin ax}{bx}</math> and <math>\frac{\tan ax}{bx}</math> where <math>a</math> and <math>b</math> are real numbers and <math>a, b \neq 0</math>. Evaluate <math>\lim_{x \rightarrow 0} \frac{\sin ax}{bx}</math> and <math>\lim_{x \rightarrow 0} \frac{\tan ax}{bx}</math>.</li> <li>Graph the functions <math>c</math> (constant), <math>x^n</math>, <math>\sin x</math>, <math>\cos x</math>, <math>\tan x</math>, <math>\operatorname{cosec} x</math>, <math>\sec x</math>, <math>\cot x</math>, <math>e^x</math> and <math>\log x</math>. Find their first derivative and second derivative.</li> </ol> <p>Note: Only two functions will be given in Board Practical Examination in subdivision-(iv) of</p>	5

<p>Ex-7.</p> <p>Ex-8: The alternating current passing through a circuit is <math>i(t) = I_m \sin \omega t</math> where, <math>I_m</math> is the maximum value of current and <math>\omega</math> is the angular velocity. Let <math>L</math> be the inductance.</p> <p>(i) Graph the sinusoidal wave form of <math>i(t)</math> for the given values of <math>I_m</math> and <math>\omega</math>.</p> <p>(ii) Graph the voltage using the formula <math>v(t) = L \frac{di(t)}{dt}</math> for the given value of <math>L</math>.</p> <p>(iii) Determine the values of <math>i(t)</math> and <math>v(t)</math> for a fixed <math>t</math> and different values of <math>\omega</math>.</p> <p>(iv) Determine the values of <math>i(t)</math> and <math>v(t)</math> for fixed value of <math>\omega</math> and different values of <math>t</math>.</p> <p>(v) Determine the values of <math>t</math> for which <math>i(t)</math> and <math>v(t)</math> are equal.</p>		6
<b>Unit V      INTEGRAL CALCULUS</b>		
<p><b>THEORY</b></p>	<p>Integration formulae of standard functions as inverse operation of differentiation – Bernoulli’s formula – Definite integrals (Properties are excluded) – Area and volume using integration – Simple problems.</p>	3
<p><b>PRACTICAL</b></p> <p>Ex-9: Do the following activities.</p> <p>i. Graph the functions <math>c</math> (constant), <math>x^n, n \in \mathbb{R}</math>, <math>e^x</math>, <math>\sin x</math>, <math>\cos x</math>, <math>\sec^2 x</math>, <math>\operatorname{cosec}^2 x</math>, <math>\sec x \tan x</math> and <math>\operatorname{cosec} x \cot x</math>. Find their indefinite integrals.</p> <p>ii. Evaluate the definite integral <math>\int_a^b f(x) dx</math> and relate it to the area under the curve <math>y = f(x)</math> between <math>x</math>-axis, <math>x = a</math> and <math>x = b</math>.</p> <p>iii. Find the volume of the solid generated by the revolution of the area bounded by <math>y = f(x)</math>, <math>x</math>-axis, <math>x = a</math> and <math>x = b</math> about <math>x</math>-axis.</p> <p>Note: Only two functions will be given in Board Practical Examination in subdivision-(i) of Ex-9.</p> <p>Ex-10: Let <math>V</math> be the voltage, <math>L</math> be the inductance and <math>R</math> be the resistance of a circuit.</p> <p>i. Graph the function of current at time <math>t</math> using the formula <math>I(t) = \frac{V}{R} \left( 1 - e^{-\frac{Rt}{L}} \right)</math>.</p> <p>ii. Graph the function of charge passing through the coil at time <math>t</math> using the formula <math>Q(t) = \int I(t) dt</math>.</p> <p>iii. Find the values of <math>I(t)</math> and <math>Q(t)</math> for given values of <math>V, L</math> and <math>R</math> at different <math>t</math> values.</p> <p>iv. Find the values of <math>I(t)</math> and <math>Q(t)</math> at a fixed time for different values of <math>V, L</math> and <math>R</math>.</p>		5
<b>TOTAL HOURS</b>		<b>75</b>

**Note:** While setting up the practical exercise questions, the course teacher/examiner shall assign appropriate functions/constants wherever they are not mentioned explicitly.

**Suggested List of Students Activities**

Other than classroom learning, the following are the suggested student related co-curricular activities which can be undertaken to accelerate the attainment of the various outcomes in this course.



- Operate a cathode-ray oscilloscope (CRO) and visualize the formation of ellipse on the screen.
- Examine a satellite dish antenna and verify that the receiver is fixed at its focus.
- Draw the phasor diagram and visualize the triangular relationship between apparent power, active power and reactive power.
- Find the height of a mountain using GeoGebra simulation of the image of the mountain.
- Find the volume of a water bottle using GeoGebra simulation of the image of the bottle.

### References

1. Higher Secondary First Year Mathematics Volume-I & Volume-II, Tamil Nadu Textbook and Educational Services Corporation, Government of Tamil Nadu, 2022.
2. Higher Secondary Second Year Mathematics Volume-I & Volume-II, Tamil Nadu Textbook and Educational Services Corporation, Government of Tamil Nadu, 2022.
3. John Bird, Higher Engineering Mathematics, Newnes (Elsevier), 6<sup>th</sup> Edition, 2010.
4. Grewal, B.S., Higher Engineering Mathematics, Khanna Publishers, 42<sup>nd</sup> Edition, 2012.
5. Deepak Singh, Mathematics-I, Khanna Book Publishing Co. (P) Ltd., 2021.
6. Garima Singh, Mathematics-II, Khanna Book Publishing Co. (P) Ltd., 2021.
7. John Vince, Calculus for Computer Graphics, Second Edition, Springer, 2019.
8. GeoGebra Manual, The Official Manual of GeoGebra (PDF Version), 2016.
9. GeoGebra Handbook for Senior Secondary Mathematics Teachers, Regional Institute of Education, Mysuru, 2016.
10. Steve Phelps, An Introduction to GeoGebra, GeoGebra Institute of Ohio, University of Cincinnati.

### Web-based/Online Resources

1. <https://www.khanacademy.org/math/>
2. <https://www.mathportal.org/>
3. <https://openstax.org/subjects/math>
4. <https://www.mathhelp.com/>
5. <https://www.geogebra.org/>
6. <https://www.desmos.com/>
7. <https://phet.colorado.edu/>

### Hardware Requirement

- Desktop Computers: 30 + 2 Nos.
- Projector and Screen
- Printer

### Software Requirement

- Operating System: Windows 7 or later
- GeoGebra Classic 5 (Free version)

### Allocation of Marks for End Semester Exam

<b>Part</b>	<b>Description</b>	<b>Marks</b>
A	Written Test (Theory Portion)	30
B	Aim	10
C	Procedure	20
D	Output	30
E	Viva-voce	10
<b>Total</b>		<b>100</b>

**Note:**

- 1) 20 questions shall be given from the theory portion, out of which 15 have to be answered. Each question carries 2 marks.
- 2) One practical exercise question shall be given for practical exam.

PH232441	<b>APPLIED PHYSICS – I [NON-CIRCUIT BRANCHES]</b>	L	T	P	C
Practicum		1	0	2	2

### Introduction

This course will give the outline of applications of some important physics principles which are relevant for non-circuit polytechnic branches.

### Course Objectives

The objective of this course is to

1. Discuss the basics of rigid body dynamics
2. Explain the properties of fluids and its relevance to technological fields
3. Outline the relevance of acoustic principles, SONAR
4. Give basics of current, voltage and ohm's law and its applications in engineering field

### Course Outcomes

After successful completion of this course, the students should be able to

- CO1: Calculate the moment of inertia, center of mass, center gravity of various objects and  
CO2: Compare the surface tension and viscosity of various engineering materials  
CO3: Formulate acoustic guidelines for buildings, mechanical structures,  
CO4: Construct simple DC circuits

### Pre-requisites

10<sup>th</sup> standard physics

## CO/PO Mapping

CO / PO	P01	P02	P03	P04	P05	P06	P07
C01	3	3	2	1	1	1	3
C02	3	3	2	1	1	1	3
C03	3	3	2	1	1	1	3
C04	3	3	2	1	1	1	3

Legend: 3-High Correlation, 2-Medium Correlation, 1-Low Correlation

## Instructional Strategy

- It is advised that teachers take steps to pique pupils' attention and boost their learning confidence.
- To help students learn and appreciate numerous concepts and principles in each area, teachers should provide examples from daily life, realistic situations, and real-world engineering and technological applications.
- The demonstration can make the subject exciting and foster in the students a scientific mindset. Student activities should be planned on all the topics.
- Throughout the course, a theory-demonstrate-practice-activity strategy may be used to ensure that learning is outcome- and employability-based.
- Do not let students work on an activity or an experiment with the expected outcome, rather allow students to be honest about whatever the results of the experiment are. If the results are different from the expectations, students should do an analysis where they could be the source of error, if any.

## Assessment Methodology

	Continuous Assessment (40 marks)					End Semester Examination (60 marks)
	CA1		CA2		CA3	
Mode	Written exam Unit 1	Practical exam 4 expts	Written exam Unit 2	Practical exam 4 expts	Model Practical exam	Practical exam
					8 expts	
Duration	1 hour	2 hours	1 hour	2 hours	3 hours	3 hours
Exam Marks	20	60	20	60	100	100
Converted to	20		20		20	60
Final marks	20				20	60

Note:

- Average of CA 1 and CA 2 should be considered for the internal assessment of 20 marks
- CA 3 Model examination should be conducted as per the End Semester guidelines. The same should be considered for the internal assessment of 20 marks

PH232441		<b>APPLIED PHYSICS – I</b> <b>[NON-CIRCUIT BRANCHES]</b>			
Practicum					
		1	-	2	2
Unit I	PROPERTIES OF RIGID BODY AND FLUIDS				
Rigid body – Centre of mass – Centre of gravity – Examples – Torque-Moment of inertia of a rigid body about an axis – Expression – radius of gyration – Moment of inertia of symmetric objects (thin rod, disc, ring, hollow and solid cylinder) – parallel and perpendicular axis theorem (no derivation)- Examples. Fluids – streamline flow, turbulent flow - critical velocity –Surface tension – application of capillarity - Viscosity -Definition and SI units- Coefficient of Viscosity – Reynolds number					6 periods
<b>Experiment #1:</b> Determination of moment of inertia of disc using torsional pendulum <b>Experiment #2:</b> Determination of moment of inertia of rigid rod about center of mass- compound pendulum <b>Experiment #3:</b> Determination of Surface tension of liquid by Capillary rise method <b>Experiment #4:</b> Determination of coefficient of Viscosity of highly viscous liquid by Stokes method					9 periods
Unit II	BASICS OF SOUND AND ELECTRICITY				
Wave motion – audible range – infrasonic and ultrasonic – longitudinal, transverse and progressive waves – standing waves – free and forced vibration – laws of transverse vibration -Sonometer – acoustics of buildings – echo – reverberation – reverberation time – Sabine formula (no derivation) – Noise pollution - Doppler effect – applications. Current – Voltage - Ohm’s law – resistance – resistivity - effective resistance - Kirchhoff current and voltage law – Wheatstone bridge - Joule’s law of heating –applications of heating effect of electric current					6 periods
<b>Experiment #5:</b> Determination of frequency of tuning fork - Sonometer. <b>Experiment #6:</b> Determination of the resistance and resistivity of a given coil - Wheatstone bridge. <b>Experiment #7:</b> Verification of laws of resistances – Ohm’s law <b>Experiment #8:</b> Determination of specific heat capacity of liquid- Joule’s calorimeter.					15 periods
<b>Test &amp; Assessment</b>					9
<b>TOTAL PERIODS</b>					<b>45</b>

### Suggested List of Students Activity

- Presentation/Seminars by students on any recent technological developments based on the course
- Periodic class quizzes conducted on a weekly/fortnightly based on the course
- Micro project that shall be an extension of any practical lab exercise to real-world application

### Reference

1. XI<sup>th</sup> and XII<sup>th</sup> standard Tamilnadu State Board Physics Text Book, 2023 edition, Textbook Corporation Tamil Nadu
2. H.C.Verma, Concepts of Physics Vol 1 & Vol 2, Bharathi Bhavan Publishers, 1st edition, 2021

### Web-based/Online Resources

1. [https://youtu.be/Jtud5iwTd\\_I?si=zTGcQdimzT0FXtzY](https://youtu.be/Jtud5iwTd_I?si=zTGcQdimzT0FXtzY)
2. [https://www.youtube.com/watch?v=nVPrWz8Jfgo&list=PLqwfRVlgGdFBVn3o5AmfJGhSv9NXM\\_XKc&ab\\_channel=khanacademymedicine](https://www.youtube.com/watch?v=nVPrWz8Jfgo&list=PLqwfRVlgGdFBVn3o5AmfJGhSv9NXM_XKc&ab_channel=khanacademymedicine)
3. [https://www.youtube.com/watch?v=ZcZQsi6YAgU&list=PLqwfRVlgGdFBHGEZdkmGzKGufuV5l3z0v&ab\\_channel=KhanAcademyPhysics](https://www.youtube.com/watch?v=ZcZQsi6YAgU&list=PLqwfRVlgGdFBHGEZdkmGzKGufuV5l3z0v&ab_channel=KhanAcademyPhysics)
4. [https://www.youtube.com/watch?v=F\\_vLWkkOETI&list=PLqwfRVlgGdFC7HLoajCVjUk23cqy4QvRL&ab\\_channel=KhanAcademy](https://www.youtube.com/watch?v=F_vLWkkOETI&list=PLqwfRVlgGdFC7HLoajCVjUk23cqy4QvRL&ab_channel=KhanAcademy)

### Allocation of marks in End semester practical and model practical exams:

S.No	Description	Marks
1	Aim	5
2	Apparatus required	5
3	Formulas, explanations, tabular column, Schematic diagram	10
4	Observations & Reading taken	50
5	Calculations	20
6	Result	5
7	Viva voce	5
	<b>Total</b>	<b>100</b>



PH232442	<b>APPLIED PHYSICS – II (CIRCUIT BRANCHES)</b>	L	T	P	C
Practicum		1	0	2	2

### Introduction

This course will give the outline of applications of some important physics and chemistry principles which are relevant for non-circuit polytechnic branches

### Course Objectives

The objective of this course is to

- Outline the relevance of acoustic principles, SONAR
- Discuss the properties of light, refractive index, optoelectronic devices
- Define Current, voltage, ohm's law and simple DC circuit
- Introduces the basics of magnetism and Faraday law of Electromagnetic induction and its applications in engineering field

### Course Outcomes

On successful completion of this course, the student will be able to

CO1: Design building structures with safe acoustic guidelines

CO2: Apply optics principles properly to understand the working of technological gadgets and computer and device interfacing

CO3: Construct simple DC circuit and troubleshoot problems in the circuits

CO4: Calculate the effective resistance in series and parallel circuits, classify the materials based on magnetic properties

### Pre-requisites

10<sup>th</sup> standard physics

### CO/PO Mapping

CO / PO	P01	P02	P03	P04	P05	P06	P07
CO1	3	3	2	1	1	1	3
CO2	3	3	2	1	1	1	3
CO3	3	3	2	1	1	1	3
CO4	3	3	2	1	1	1	3

Legend: 3-High Correlation, 2-Medium Correlation, 1-Low Correlation

### Instructional Strategy

- It is advised that teachers take steps to pique pupils' attention and boost their learning confidence.



- To help students learn and appreciate numerous concepts and principles in each area, teachers should provide examples from daily life, realistic situations, and real-world engineering and technological applications.
- The demonstration can make the subject exciting and foster in the students a scientific mindset. Student activities should be planned on all the topics.
- Throughout the course, a theory-demonstrate-practice-activity strategy may be used to ensure that learning is outcome- and employability-based.
- Do not let students work on an activity or an experiment with the expected outcome, rather allow students to be honest about whatever the results of the experiment are. If the results are different from the expectations, students should do an analysis where they could be the source of error, if any.

### Assessment Methodology

	Continuous Assessment (40 marks)					End Semester Examination (60 marks)
	CA1		CA2		CA3	
Mode	Written exam Unit 1	Practical exam 4 expts	Written exam Unit 2	Practical exam 4 expts	Model Practical exam	Practical exam
					8 expts	
Duration	1 hour	2 hours	1 hour	2 hours	3 hours	3 hours
Exam Marks	20	60	20	60	100	100
Converted to	20		20		20	60
Final marks	20				20	60

#### Note:

- Average of CA 1 or CA 2 mark should be considered for the internal assessment of 20 marks
- CA 3 Model examination should be conducted as per the End Semester guidelines. The same should be considered for the internal assessment of 20 marks.

PH232442	<b>APPLIED PHYSICS – II (CIRCUIT BRANCHES)</b>	L	T	P	C
Practicum		1	0	2	2
<b>Unit I</b>	<b>SOUND &amp; OPTICS</b>				
Wave motion – audible range – infrasonic and ultrasonic – longitudinal, transverse and progressive waves – standing waves – free and forced vibration – Sonometer – acoustics of buildings – echo – reverberation – reverberation time – Sabine formula (no derivation) – Noise pollution – Doppler effect – applications.					6
Reflection - Refraction – laws of reflection and refraction – refractive index of a medium – Total internal reflection – fiber optics –applications – Laser – Principle – applications – point lasers – remote sensing – RADAR – principle and applications – Sensors – Basics – various types – applications – Optoelectronic devices					
<b>Experiment #1:</b> Determination of Refractive index of the glass plate using pin & paper <b>Experiment #2:</b> Determination of Refractive index of water using travelling microscope <b>Experiment #3:</b> Determination of frequency of tuning fork - Sonometer					9
<b>Unit II</b>	<b>BASICS OF ELECTRICITY AND MAGNETISM</b>				
Current- Voltage - Ohm’s law – resistance – resistivity - effective resistance - Kirchhoff current and voltage law - Internal resistance of the cell - Joule’s law of heating – applications of heating effect of electric current					6
Faraday law of electromagnetic induction – Inductor – self & mutual Inductance - applications – bar magnets - Pole strength – Magnetic moment –intensity of magnetization – magnetic field - types of magnetic materials and applications					
<b>Experiment #4:</b> Verification of laws of resistances – Ohm’s law <b>Experiment #5:</b> Determination of internal resistance of the cell - potentiometer <b>Experiment #6:</b> Determination of specific heat capacity of liquid - Joule’s calorimeter. <b>Experiment #7:</b> Draw the V-I characteristics of solar cell and find the efficiency <b>Experiment #8:</b> Comparison of magnetic moments of two small bar magnets - deflection magnetometer in Tan A position by equal distance method					15
<b>Test &amp; Assessment</b>					9
<b>TOTAL HOURS</b>					<b>45</b>

### **Suggested List of Students Activities:**

Other than classroom learning, the following are the suggested student related co-curricular activities which can be undertaken to accelerate the attainment of the various outcomes in this course.

- Presentation/Seminars by students on any recent technological developments based on the course
- Periodic class quizzes conducted on a weekly/fortnightly based on the course
- Micro project that shall be an extension of any practical lab exercise to real-world application

### **References:**

1. XI<sup>th</sup> and XII<sup>th</sup> standard Tamilnadu State Board Physics Text Book, 2023 edition, Textbook Corporation Tamil Nadu
2. H.C.Verma, Concepts of Physics Vol 1 & Vol 2, Bharathi Bhavan Publishers, 1st edition, 2021

### **Web-based/Online Resources:**

1. [https://www.youtube.com/watch?v=nVPrWz8Jfgo&list=PLqwfRVlgGdFBVn3o5AmfJGhSv9NXM\\_XKc&ab\\_channel=khanacademymedicine](https://www.youtube.com/watch?v=nVPrWz8Jfgo&list=PLqwfRVlgGdFBVn3o5AmfJGhSv9NXM_XKc&ab_channel=khanacademymedicine)
2. [https://www.youtube.com/watch?v=ZcZQsj6YAgU&list=PLqwfRVlgGdFBHGEZdkmGzKGufuV5I3z0v&ab\\_channel=KhanAcademyPhysics](https://www.youtube.com/watch?v=ZcZQsj6YAgU&list=PLqwfRVlgGdFBHGEZdkmGzKGufuV5I3z0v&ab_channel=KhanAcademyPhysics)
3. [https://www.youtube.com/watch?v=F\\_vLWkkOETI&list=PLqwfRVlgGdFC7HLoajCVjUk23cqy4QvRL&ab\\_channel=KhanAcademy](https://www.youtube.com/watch?v=F_vLWkkOETI&list=PLqwfRVlgGdFC7HLoajCVjUk23cqy4QvRL&ab_channel=KhanAcademy)

**Allocation of marks in End semester practical and model practical exams:**

S.No	Description	Marks
1	Aim	5
2	Apparatus required	5
3	Formulas, explanations, tabular column, Schematic diagram	10
4	Observations & Reading taken	50
5	Calculations	20
6	Result	5
7	Viva voce	5
<b>Total</b>		<b>100</b>

**Allocation of marks in CA 1 & CA2 practical exams:**

S.No	Description	Marks
1	Aim	2
2	Apparatus required	2
3	Formulas, explanations, tabular column, Schematic diagram	6
4	Observations & Reading taken	25
5	Calculations	10
6	Result	5
7	Observation note book	10
<b>Total</b>		<b>60</b>

**Allocation of marks in CA 1 & CA 2 theory exams:**

Part A: 7 questions: 5 questions have to be answered,      5 X 2 = 10 marks

Part B: 3 questions: 2 questions have to answered,      2 X 5 = 10 marks

-----  
**Total**              **20 marks**  
 -----

CH232451	<b>APPLIED CHEMISTRY – I [NON-CIRCUIT BRANCHES]</b>	L	T	P	C
Practicum		1	0	2	2

### Introduction

This course will give the outline of applications of some important physics and chemistry principles which are relevant for non-circuit polytechnic branches

### Course Objectives

The objective of this course is

1. To acquire skill on water quality parameter and art of water monitoring.
2. To understand basic knowledge on soft and hard water -EDTA experiment and scale formation.
3. To understand the harmful effects of heavy metal ions effluents and their health hazards.
4. To build understanding on methods of softening hard water- Ion exchange and reverse osmosis method and purification of drinking water.

### Course Outcomes

After successful completion of this course, the students should be able to

CO1: Differentiate hard and soft water and estimate the total hardness in the given sample

CO2: Adopt suitable cost-effective methods for the softening of hard water

CO3: Identify the reasons for the hardness and check the standard of water quality parameters

CO4: Design a suitable model to address the disadvantage boiler scales

### Pre-requisites

10<sup>th</sup> standard chemistry

### CO/PO Mapping

CO / PO	P01	P02	P03	P04	P05	P06	P07
CO1	3	3	2	1	1	1	3
CO2	3	3	2	1	1	1	3
CO3	3	3	2	1	1	1	3
CO4	3	3	2	1	1	1	3

<b>C05</b>	3	3	2	1	1	1	3
------------	---	---	---	---	---	---	---

Legend: 3-High Correlation, 2-Medium Correlation, 1-Low Correlation

### Instructional Strategy

- It is advised that teachers take steps to pique pupils' attention and boost their learning confidence.
- To help students learn and appreciate numerous concepts and principles in each area, teachers should provide examples from daily life, realistic situations, and real-world engineering and technological applications.
- The demonstration can make the subject exciting and foster in the students a scientific mindset. Student activities should be planned on all the topics.
- Throughout the course, a theory-demonstrate-practice-activity strategy may be used to ensure that learning is outcome- and employability-based.
- Do not let students work on an activity or an experiment with the expected outcome, rather allow students to be honest about whatever the results of the experiment are. If the results are different from the expectations, students should do an analysis where they could be the source of error, if any.

### Assessment Methodology

	Continuous Assessment (40 marks)					End Semester Examination (60 marks)
	CA1		CA2		CA3	
Mode	Written exam Unit 1	Practical exam 4 expts	Written exam Unit 2	Practical exam 4 expts	Model Practical exam	Practical exam
					8 expts	
Duration	1 hour	2 hours	1 hour	2 hours	3 hours	3 hours
Exam Marks	20	60	20	60	100	100
Converted to	20		20		20	60
Final marks	20				20	60

Note:

- Average of CA 1 and CA 2 should be considered for the internal assessment of 20 marks
- CA 3 Model examination should be conducted as per the End Semester guidelines. The same should be considered for the internal assessment of 20 marks

CH232451		<b>APPLIED CHEMISTRY – I [NON-CIRCUIT BRANCHES]</b>	L	T	P	C
Practicum			1	0	2	2
<b>Unit I</b>	<b>WATER ANALYSIS</b>					
Sources of water – depletion of underground water – Reasons – Basic Idea of rain water harvesting - Hard water and soft water – Hardness of water – Carbonate and Non-carbonate hardness – Methods of expressing hardness – mg/lit and ppm – Estimation of total hardness by EDTA method –simple Problems on total hardness only-Disadvantages of using hard water in boilers –Scale formation, Corrosion of boiler metal, Caustic Embrittlement – Priming and Foaming (definition only).			6 periods			
<b>Experiment #1:</b> Estimation of total hardness of water by EDTA method <b>Experiment #2:</b> Determination of alkalinity of sample of hard water <b>Experiment #3:</b> Estimation of residual chlorine in a given water sample <b>Experiment #4:</b> Estimation of oxalic acid by permanganometry			12 periods			
<b>Unit II</b>	<b>WATER TREATMENT</b>					
Determination of residual chlorine in the given sample of hard water- identification of sulphate and chloride ions- identification of heavy metal ions in the given sample of effluent- Softening of hard water – Ion-Exchange method and Reverse Osmosis method – chemical methods of purification of water- Municipal supply – purification of drinking water – Calculation of pH, H <sup>+</sup> ions and TDS of different samples of acid and base – Quality of portable water (WHO Standard)			6 periods			
<b>Experiment #5:</b> Calculation of pH, H <sup>+</sup> ion and TDS of different samples of acid and bases <b>Experiment #6:</b> Estimation of copper by Complexometry <b>Experiment #7:</b> Effluent analysis of heavy metal ions - lead, copper & zinc <b>Experiment #8:</b> Analysis of acid radicals such as carbonate, nitrate and sulphate ions.			12 periods			
<b>Test &amp; Assessment</b>			9 periods			
<b>TOTAL PERIODS</b>			<b>45</b>			

### Suggested List of Students Activity

- Presentation/Seminars by students on any recent technological developments based on the course
- Periodic class quizzes conducted on a weekly/fortnightly based on the course
- Micro project that shall be an extension of any practical lab exercise to real-world application

## Reference

1. XI<sup>th</sup> and XII<sup>th</sup> standard Tamilnadu State Board Chemistry Text Book, 2023 edition, Textbook Corporation Tamil Nadu
2. Essentials of Physical Chemistry, Bahl & Tuli, 28th edition, S.Chand Publishing House.
3. A textbook of Engineering Chemistry, Dr.Sunita Rattan, 2020 reprint, S.K.Kataria&Sons
4. Textbook of Physical Chemistry, P.L.Soni,O.P.Dharmarha & U.N.Dash,2022 edition, S.Chand Publishing House.

## Web-based/Online Resources

1. <https://libguides.lib.msu.edu/chemistry/teachonline>
2. <https://www.khanacademy.org/science/chemistry>
3. <https://phet.colorado.edu/>
4. <https://www.sciencebysimulation.com/chemreax/Faq.aspx>
5. [www.olabs.gov.in](http://www.olabs.gov.in)

## Allocation of marks in End semester practical exam – and model practical exam

### ➤ For experiment no. 1,2,3,4 and 6

S.No	Description	Marks
1	Short procedure	5
2	Titration I	35
3	Titration II	35
4	Calculation	15
5	Result & Viva	10
	<b>Total</b>	<b>100</b>

### Skill value

- Less than 2 % with correct tabular column and details - 35 marks
- More than 3%. - 10 marks
- More than 4% - 5 marks
- Wrong tabular column even if reading is correct - only 5 marks

### ➤ For experiment no. 5

Description	
Definition of pH and formula	10
Water quality parameters	15



pH reading for 3 samples	10
Calculation of hydrogen ion concentration	30
TDS reading for 3 samples	20
Calculation and Result	15
Total	100

➤ **For experiment no.7 Effluent analysis**

Description	
Definition	5
Any three test for 3 effluents	45
Any five sources for each effluent	20
Any five Harmful effects for each	20
Report	10
total	100

➤ **For experiment no.8 Analysis of acid radicals**

Description	
Identification of three acid radicals with two tests for each	60
Confirmatory test for each radical	30
Report	10
Total	100

**Allocation of marks in CA 1 and CA 2 practical exams**

➤ **For experiment no. 1,2 3,4 and 6**

S.No	Description	Marks
1	Short procedure	5

<b>2</b>	<b>Titration I</b>	<b>15</b>
<b>3</b>	<b>Titration II</b>	<b>15</b>
<b>4</b>	<b>Calculation</b>	<b>10</b>
<b>5</b>	<b>Result</b>	<b>5</b>
<b>6</b>	<b>Observation note book</b>	<b>10</b>
	<b>total</b>	<b>60</b>

Skill value

- Less than 2 % with correct tabular column and details - 15 marks
- More than 3%. - 10 marks
- More than 4% - 5 marks
- Wrong tabular column even if reading is correct - only 5 marks

➤ **For experiment no. 5**

External Examination	
Definition of pH and formula	5
Water quality parameters	10
pH reading for 3 samples	5
Calculation of hydrogen ion concentration	20
TDS reading for 3 samples	5
Calculation and Result	5
Observation note book	10
Total	60

➤ **For experiment no.7 Effluent analysis**

External Examination	
Definition	5

Any three test for 3 effluent	20
Any five sources for each effluent	10
Any five Harmful effects for each	10
Report	5
Observation note book	10
Total	60

➤ **For experiment no.8 Analysis of acid radicals**

External Examination	
Identification of three acid radicals with two tests for each	25
Confirmatory test for each radical	20
Report	5
Observation notebook	10
Total	60

**Allocation of marks in CA 1 & CA 2 theory exams:**

<b>Part A: 7 questions: 5 questions have to be answered,</b>	<b>5 X 2 = 10 marks</b>
<b>Part B: 3 questions: 2 questions have to answered,</b>	<b>2 X 5 = 10 marks</b>
	-----
<b>Total</b>	<b>20 marks</b>
	-----

CH232452	<b>APPLIED CHEMISTRY – II (CIRCUIT BRANCHES)</b>	L	T	P	C
Practicum		1	0	2	2

### Introduction

This course will give the outline of applications of some important physics and chemistry principles which are relevant for non-circuit polytechnic branches

### Course Objectives

The objective of this course is to

- Analyze soft and hard water, EDTA titrations on hardness of water and boiler scale formation.
- To empower the learner with the fundamental knowledge on components of battery and working.
- To understand the process of electroplating and appreciate the role of electroplating in daily life.
- To build understanding on methods of softening hard water- Ion exchange and reverse osmosis method and drinking water quality parameters (WHO).

### Course Outcomes

On successful completion of this course, the student will be able to

CO1: Differentiate hard water and soft water and reason out the salts responsible for hardness

CO2: Compare the hardness of water samples in different regions

CO3: Identify and apply the methods for effective conversion of hard water into soft water

CO4: Construct the electroplating model and apply the concept in daily life situations

### Pre-requisites

10<sup>th</sup> standard chemistry

### CO/PO Mapping

CO / PO	P01	P02	P03	P04	P05	P06	P07
CO1	3	3	2	1	1	1	3
CO2	3	3	2	1	1	1	3
CO3	3	3	2	1	1	1	3
CO4	3	3	2	1	1	1	3

Legend: 3-High Correlation, 2-Medium Correlation, 1-Low Correlation

### Instructional Strategy

- It is advised that teachers take steps to pique pupils' attention and boost their learning confidence.

- To help students learn and appreciate numerous concepts and principles in each area, teachers should provide examples from daily life, realistic situations, and real-world engineering and technological applications.
- The demonstration can make the subject exciting and foster in the students a scientific mindset. Student activities should be planned on all the topics.
- Throughout the course, a theory-demonstrate-practice-activity strategy may be used to ensure that learning is outcome- and employability-based.
- Do not let students work on an activity or an experiment with the expected outcome, rather allow students to be honest about whatever the results of the experiment are. If the results are different from the expectations, students should do an analysis where they could be the source of error, if any.

### Assessment Methodology

	Continuous Assessment (40 marks)					End Semester Examination (60 marks)
	CA1		CA2		CA3	
Mode	Written exam Unit 1	Practical exam 4 expts	Written exam Unit 2	Practical exam 4 expts	Model Practical exam	Practical exam
					8 expts	8 expts
Duration	1 hour	2 hours	1 hour	2 hours	3 hours	3 hours
Exam Marks	20	60	20	60	100	100
Converted to	20		20		20	60
Final marks	20				20	60

Note:

- Average of CA 1 and CA 2 should be considered for the internal assessment of 20 marks
- CA 3 Model examination should be conducted as per the End Semester guidelines. The same should be considered for the internal assessment of 20 marks

CH232452	<b>APPLIED CHEMISTRY – II (CIRCUIT BRANCHES)</b>	L	T	P	C
Practicum		1	0	2	2
<b>Unit I</b>	<b>WATER ANALYSIS AND TREATMENT</b>				
Sources of water – depletion of underground water – Reasons - Hard water and soft water – Hardness of water – Carbonate and Non-carbonate hardness – Methods of expressing hardness – mg/lit and ppm – Estimation of total hardness by EDTA method –simple Problems on total hardness only – identification of sulphate and chloride ions- identification of heavy metal ions in the given sample of effluent- Softening of hard water – Ion-Exchange method and Reverse Osmosis-Calculation of pH, H <sup>+</sup> ion and TDS of different samples of acid and base					6
<b>Experiment #1:</b> Estimation of total hardness of water by EDTA method <b>Experiment #2:</b> Determination of alkalinity of sample of hard water <b>Experiment #3:</b> Estimation of residual chlorine in a given water sample <b>Experiment #4:</b> Estimation of copper by Complexometry					12
<b>Unit II</b>	<b>BATTERIES AND CELLS</b>				
Metallic and electrolytic conduction –differences- Faradays laws of electrolysis- electronic concept of oxidation and reduction - electroplating- definition- examples-chrome plating, copper plating and galvanization-Energy sources – Primary and secondary battery-electrochemical cell – construction and working of dry cell – lead acid battery - advantages construction and working of solar cell.					6
<b>Experiment #5:</b> Calculation of pH, H <sup>+</sup> ion and TDS of different samples of acids and bases. <b>Experiment #6:</b> Effluent analysis of heavy metal ions - lead, copper & zinc <b>Experiment #7:</b> Process of electroplating – copper plating by Joules calorimeter <b>Experiment #8:</b> Analysis of acid radicals such as carbonate, nitrate and sulphate ions.					12
<b>Test &amp; Revision</b>					9
<b>TOTAL HOURS</b>					<b>45</b>

#### Suggested List of Students Activities:

Other than classroom learning, the following are the suggested student related co-curricular activities which can be undertaken to accelerate the attainment of the various outcomes in this course.

- Presentation/Seminars by students on any recent technological developments based on the course
- Periodic class quizzes conducted on a weekly/fortnightly based on the course
- Micro project that shall be an extension of any practical lab exercise to real-world application

#### References:

1. XI<sup>th</sup> and XII<sup>th</sup> standard Tamilnadu Chemistry Text Book, 2023 edition, Textbook

Corporation Tamil Nadu

- Essentials of Physical Chemistry, Bahl & Tuli, 28th edition, S.Chand Publishing House.
- A textbook of Engineering Chemistry, Dr.Sunita Rattan, 2020 reprint, S.K.Kataria&Sons
- Textbook of Physical Chemistry, P.L Soni,O.P.Dharmarha & U.N.Dash,2022 edition, S.Chand Publishing House.

**Web-based/Online Resources:**

- <https://libguides.lib.msu.edu/chemistry/teachonline>
- <https://www.khanacademy.org/science/chemistry>
- <https://phet.colorado.edu/>
- <https://www.sciencebysimulation.com/chemreax/Faq.aspx>
- [www.olabs.gov.in](http://www.olabs.gov.in)

**Allocation of marks in End semester practical exam – and Model exam**

➤ For experiment no. 1,2,3,4,

S.No	Description	Marks
1	Short procedure	5
2	Titration I	35
3	Titration II	35
4	Calculation	15
5	Result & Viva	10
	<b>Total</b>	<b>100</b>

Skill value

- Less than 2 % with correct tabular column and details - 35 marks
- More than 3%. - 10 marks
- More than 4% - 5 marks
- Wrong tabular column even if reading is correct - only 5 marks

➤ For experiment no. 5

Description	
Definition of pH and formula	10
Water quality parameters	15
pH reading for 3 samples	10
Calculation of hydrogen ion concentration	30
TDS reading for 3 samples	20

Calculation and Result	15
Total	100

➤ **For experiment no.6 Effluent analysis**

Description	
Definition	5
Any three test for 3 effluent	45
Any five sources for each effluent	20
Any five Harmful effects for each	20
Report	10
Total	100

➤ **For experiment no. 7 for circuit branches (Electroplating)**

Description	
Electroplating- definition of chromplating, copper plating and galvanization	15
Apparatus required	5
Anode cathode and electrolyte	10
Circuit diagram	20
Cell reaction at anode	20
Cell reaction at cathode	20
Report	10
Total	100

➤ **For experiment no.8 Analysis of acid radicals**

Description	
Identification of three acid radicals with two test for each	60
Confirmatory test for each radicals	30
Report	10



Total	100
-------	-----

**Allocation of marks for CA 1 and CA 2 practical exams only**

➤ For experiment no. 1,2,3,4,

S.No	Description	Marks
1	Short procedure	5
2	Titration I	15
3	Titration II	15
4	Calculation	10
5	Result	5
6	Observation note book	10
	<b>Total</b>	<b>60</b>

Skill value

- Less than 2 % with correct tabular column and details - 15 marks
- More than 3%. - 10 marks
- More than 4% - 5 marks
- Wrong tabular column even if reading is correct - only 5 marks

➤ For experiment no. 5

Description	
Definition of pH and formula	5
Water quality parameters	10
pH reading for 3 samples	5
Calculation of hydrogen ion concentration	20
TDS reading for 3 samples	5
Calculation and Result	5
Observation notebook	10
<b>Total</b>	<b>60</b>

➤ **For experiment no.6 Effluent analysis**

Description	
Definition	5
Any three test for 3 effluent	20
Any five sources for each effluent	10
Any five Harmful effects for each	10
Report	5
Observation notebook	10
Total	60

➤ **For experiment no. 7 for circuit branches (Electroplating)**

Description	
Electroplating- definition of chromplating, copper plating and galvanization	3
Apparatus required	2
Anode cathode and electrolyte	5
Circuit diagram	15
Cell reaction at anode	10
Cell reaction at cathode	10
Report	5
Observation note book	10
Total	60

➤ **For experiment no.8 Analysis of acid radicals**

Description	
Identification of three acid radicals with two test for each	20
Confirmatory test for each radicals	20
Report	10

Observation notebook	10
Total	60

**Allocation of marks in CA 1 & CA 2 theory exams:**

<b>Part A: 7 questions: 5 questions have to be answered,</b>	<b>5 X 2 = 10 marks</b>
<b>Part B: 3 questions: 2 questions have to answered,</b>	<b>2 X 5 = 10 marks</b>
	-----
<b>Total</b>	<b>20 marks</b>
	-----

TA232110	தமிழரும் தொழில்நுட்பமும் (Tamils and Technology)	L	T	P	C
Theory		2	-	-	2

**Introduction:**

This course provides an opportunity for students who have Tamil as their mother tongue and for students from other states to have multifold outcomes. Learning in the mother tongue is a key factor for inclusion and quality learning, and it also improves learning outcomes and academic performance. This is crucial, for appreciation of Tamil as a language and as a culture. It fosters mutual understanding and respect for one another and helps preserve the wealth of cultural and traditional heritage that is embedded in Tamil language around the world.

**Course Objectives:** The objective of this course is to enable the student to

1. Appreciate weaving and ceramic technology
2. Learn the design and construction technology of ancient times
3. understand the engineering principles of manufacturing technology
4. introduce the methods of irrigation and agricultural technology
5. learn the scientific tamil and tamil computing

**Course Outcomes:**

After successful completion of this course, the students should be able to

CO1: explain the principles behind weaving and ceramic technology of ancient tamils

CO2: correlate the present and ancient design and construction technology

CO3: apply engineering principles to ancient manufacturing technology

CO4: apply engineering principles to irrigation and agricultural technology

CO5: develop scientific tamil and new techniques in tamil computing

**Assessment Methodology**

	Continuous Assessment (40 marks)				End Semester Examination (60 marks)
	CA1	CA2	CA3	CA4	
Mode	Written Test (unit 1 & 2)	Written Test (unit 3 & 4)	Quiz / MCQ	Model Examination	Written Examination

Duration	2 hours	2 hours	1 hour	3 hours	3 hours
Exam Marks	60	60	40	100	100
Converted to	20	20	10	10	60
Marks	40				60

**Note:**

- CA1 and CA2 Assessment test should be conducted. Best of one will be considered for the internal assessment of 20 Marks.
- CA3 Online quiz examination (MCQ) should be conducted covering the complete syllabus. The marks should be converted to 10 marks for the internal assessment
- CA4 Model examination should be conducted as per the end semester question pattern. The marks should be converted to 10 marks for the internal assessment.

<b>TA232110</b>	<b>தமிழரும் தொழில்நுட்பமும் (Tamils and Technology)</b>	L	T	P	C
<b>Theory</b>		2	-	-	2
<b>Unit I</b>	<b>WEAVING AND CERAMIC TECHNOLOGY</b>				
Weaving Industry during Sangam Age – Ceramic technology – Black and Red Ware Potteries (BRW) – Graffiti on Potteries.					
<b>Unit II</b>	<b>DESIGN AND CONSTRUCTION TECHNOLOGY</b>				
Designing and Structural construction House & Designs in household materials during Sangam Age - Building materials and Hero stones of Sangam age – Details of Stage Constructions in Silappathikaram - Sculptures and Temples of Mamallapuram - Great Temples of Cholas and other worship places - Temples of Nayaka Period - Type study (Madurai Meenakshi Temple)- Thirumalai Nayakar Mahal - Chetti Nadu Houses, Indo - Saracenic architecture at Madras during British Period.		8 periods			
<b>Unit III</b>	<b>MANUFACTURING TECHNOLOGY</b>				
Art of Ship Building - Metallurgical studies - Iron industry - Iron smelting, steel -Copper and gold coins as source of history - Minting of Coins – Beads making-industries Stone beads -Glass beads - Terracotta beads -Shell beads/ bone beads - Archeological evidences - Gem stone types described in Silappathikaram.		7 periods			
<b>Unit IV</b>	<b>AGRICULTURE AND IRRIGATION TECHNOLOGY</b>				

Dam, Tank, ponds, Sluice, Significance of Kumizhi Thoompou of Chola Period, Animal Husbandry - Wells designed for cattle use - Agriculture and Agro Processing - Knowledge of Sea - Fisheries – Pearl - Conche diving - Ancient Knowledge of Ocean - Knowledge Specific Society.	periods
<b>Unit V</b>	<b>SCIENTIFIC TAMIL AND TAMIL COMPUTING</b>
Development of Scientific Tamil - Tamil computing – Digitalization of Tamil Books – Development of Tamil Software – Tamil Virtual Academy – Tamil Digital Library – Online Tamil Dictionaries – Sorkuvai Project	
<b>TOTAL PERIODS</b>	<b>90</b>

TA232110	தமிழரும் தொழில்நுட்பமும் (Tamils and Technology)	L	T	P	C
Theory		2	-	-	2
<b>அலகு I</b>	<b>நெசவு மற்றும் பானைத்தொழில்நுட்பம்</b>				
சங்க காலத்தில் நெசவுத்தொழில்- பானைத்தொழில் நுட்பம் - கருப்பு சிவப்பு பாண்டங்கள் - பாண்டங்களில் கீறல் குறியீடுகள்					5 periods
<b>Unit II</b>	<b>வடிவமைப்பு மற்றும் கட்டிடத் தொழில்நுட்பம்</b>				
சங்க காலத்தில் வடிவமைப்பு மற்றும் கட்டுமானங்கள் வடிவமைப்பு மற்றும் கட்டிடத் தொழில்நுட்பம் சங்க காலத்தில் வடிவமைப்பு மற்றும் கட்டுமானங்கள் & சங்க காலத்தில் வீட்டுப் பொருட்களில் வடிவமைப்பு - சங்க காலத்தில் கட்டுமான பொருட்களும் நடுகல்லும் - சிலப்பதிகாரத்தில் மேடை அமைப்பு பற்றிய விவரங்கள் - மாமல்லபுரச் சிற்பங்களும், கோவில்களும் - சோழர் காலத்துப் பெருங்கோயில்கள் மற்றும் விற வழிபாட்டுத் தலங்கள் - நாயக்கர் காலக் கோயில்கள் - மாதிரி கட்டமைப்புகள் பற்றி அறிதல், மதுரை மீனாட்சி அம்மன் ஆலயம் மற்றும் திருமலை நாயக்கர் மஹால் - செட்டிநாட்டு வீடுகள் - பிரிட்டிஷ் காலத்தில் சென்னையில் இந்தோ-சாரோசெனிக் கட்டிடக் கலை.					7 periods
<b>Unit III</b>	<b>உற்பத்தி தொழில்நுட்பம்</b>				
கப்பல் கட்டும் கலை - உலோகவியல் - இரும்பு தொழிற்சாலை - இரும்பை உருக்குதல், எஃகு - வரலாற்றுச் சான்றுகளாக செம்பு மற்றும் தங்க நாணயங்கள் - நாணயங்கள் அச்சடித்தல் - மணி உருவாக்கும் தொழிற்சாலைகள் - கல்மணிகள், கண்ணாடி மணிகள் - சுடுமண் மணிகள் - சங்கு மணிகள் - எலும்புத் துண்டுகள் - தொல்லியல் சான்றுகள் - சிலப்பதிகாரத்தில் மணிகளின் வகைகள்.					6 periods
<b>Unit IV</b>	<b>வேளாண்மை மற்றும் நீர்ப்பாசனத் தொழில்நுட்பம்</b>				
அணை, ஏரி, குளங்கள், மதகு - சோழர் காலக் குழுழித் தூம்பின் முக்கியத்துவம் - கால்நடை பராமரிப்பு - கால்நடைகளுக்காக வடிவமைக்கப்பட்ட கிணறுகள் - வேளாண்மை மற்றும் வேளாண்மைச் சார்ந்த செயல்பாடுகள் - கடல்சார் அறிவு -					6 periods

மீன்வளம் - முத்து மற்றும் முத்துக்குளித்தல் - பெருங்கடல் குறித்த பண்டைய அறிவு - அறிவுசார் சமூகம்.		
<b>Unit V</b>	<b>அறிவியல் தமிழ் மற்றும் கணித்தமிழ்</b>	
அறிவியல் தமிழின் வளர்ச்சி - கணித்தமிழ் வளர்ச்சி - தமிழ் நூல்கள் மின்பதிப்பு செய்தல் - தமிழ் மென்பொருட்கள் உருவாக்கம் - தமிழ் இணையக் கல்விக்கழகம் - தமிழ் மின் நூலகம் - இணையத்தில் தமிழ் அகராதிகள் - சொற்குவைத்திட்டம்		6 periods
<b>TOTAL PERIODS</b>		<b>30</b>

### Reference

1. தமிழக வரலாறு - மக்களும் பண்பாடும் - கே.கே.பிள்ளை (வெளியீடு: தமிழக வரலாறு - மக்களும் பண்பாடும் - கே.கே.பிள்ளை (வெளியீடு: தமிழ்நாடு பாடநூல் மற்றும் கல்வியியல் பணிகள் கழகம்)
2. கணினித் தமிழ் - முனைவர் இல.சுந்தரம் (விகடன் பிரசுரம்)
3. கீழடி - வைகை நதிக்கரையில் சங்ககால நகர நாகரிகம் (தொல்லியல் துறை வெளியீடு)
4. பொருளை - ஆற்றங்கரை நாகரிகம் (தொல்லியல் துறை வெளியீடு)
5. Social Life of Tamils (Dr.K.K.Pillay) A joint publication of TNTB & ESC and RMRL - (in print)
6. Social Life of the Tamils - The Classical Period (Dr.S.Singaravelu) (Published by: International Institute of Tamil Studies.
7. Historical Heritage of the Tamils (Dr.S.V.Subatamanian, Dr.K.D. Thirunavukkarasu) (Published by: International Institute of Tamil Studies).
8. The Contributions of the Tamils to Indian Culture (Dr.M.Valarmathi) (Published by: International Institute of Tamil Studies.)
8. Keeladi - 'Sangam City Civilization on the banks of river Vaigai' (Jointly Published by Department of Archaeology & Tamil Nadu Text Book and Educational Services



Corporation, Tamil Nadu)

9. Studies in the History of India with Special Reference to Tamil Nadu  
(Dr.K.K.Pillay) (Published by: The Author)
10. Porunai Civilization (Jointly Published by: Department of Archaeology & Tamil  
Nadu Text Book and Educational Services Corporation, Tamil Nadu)
11. Journey of Civilization Indus to Vaigai (R.Balakrishnan) (Published by: Roja  
Muthiah Research Library)

EN232480	<b>COMMUNICATIVE ENGLISH - II</b>	L	T	P	C
Practicum		1	0	2	2

## Introduction

Communication is the foundation for all human relationships and language is one of the prime tools of communication. Communication is reliant on cognitive skills such as eloquent speech, vocabulary, reading comprehension and critical thinking. The present syllabus focuses on four Language Skills Listening, Speaking, Reading, and Writing. It enables the students to shed their inhibitions be confident in their approach and acquire the skills to build good working relationships in their career. It helps the student at the Diploma level to gain confidence and enhance them to face their career commitments with globalized standards.

## Course Objectives

The objective of this course is to enable the students to

- Improve the communicative competence in English.
- Enhance the vocabulary and LSRW Skills.
- Foster their confidence in group communication skills.
- Learn the techniques of effective writing.
- Enable them to communicate effectively and appropriately in real-life situations.

## Course Outcomes

On successful completion of this course, the students will be able to

**C01:** Boost confidence in expressing ideas, and plans, interpreting the same in social and professional situations.

**C02:** Frame grammatically correct sentences with clarity and coherence both in oral and written communication.

**C03:** Analyze and evaluate the information with supporting ideas logically and coherently.

**C04:** Communicate effectively using appropriate vocabulary and grammar in every situational context.

**C05:** Provide adequate exposure and opportunities to imbibe, develop, practice and use LSRW skills and seek opportunities for further language development outside the classroom.

### Pre-requisites

NIL

### CO/PO Mapping

CO / PO	P01	P02	P03	P04	P05	P06	P07
C01	-	-	-	-	-	3	2
C02	-	-	-	-	-	3	2
C03	-	-	-	-	-	3	2
C04	-	-	-	-	-	3	2
C05	-	-	-	-	-	3	2

*Legend: 3-High Correlation, 2-Medium Correlation, 1-Low Correlation*

### Instructional Strategy

The instructional strategy for Communicative English classes employs a learner-centred and communicative approach that focuses on active student participation and engagement. Here are some key strategies to be followed.

- **Communicative Activities:** Activities that develop active vocabulary and encourage role plays and language games for everyday applications.
- **Pair and Group work:** Promotes student interaction in a confident way in day-to-day conversation. It also reinforces their language skills through communication with their peers.
- **Authentic Materials:** News articles, videos, and podcasts develop comprehension and critical thinking skills.
- **Task-Based Learning:** Implement task-based learning activities for students and use English for real-world purposes.
- **Language Output and Output Balance:** Ensure a balance between language input like exposure to domain-specific vocabulary and grammar structures with examples. Enable language output by giving opportunities for students to build both receptive skills (**Listening and Reading**) and productive skills (**Speaking and Writing**).

- **Use of Technology:** Technology tools and resources such as language learning apps, online platforms, and virtual communication tools can be used to provide practice opportunities.
- **Regular Assessment:** Formative and Summative assessments are conducted to gauge students' progress and encourage them in their language learning journey

	Continuous Assessment (40 marks)				End Semester Examination (60 marks)	
	CA1	CA2	CA3	CA4		
Mode	Written Test (Theory + Writing Skill)  UNIT I & II	Written Test (Theory + Writing Skill)  UNIT III, IV&V	MODEL EXAM  Oral (S, R)*  (Unit I, II, III, IV&V)	MODEL EXAM  Written (Theory, L, W)*  (Unit I, II,III, IV,V)	Oral Exam  (S,R)*	Written Exam  (Theory L,W)*
Duration	2 hours	2 hours	2 hours	2 hours	3 hours	
Exam Marks	30 +10 (Record Marks -Unit I & II)	30 +10 (Record Marks- Unit III, IV, V)	50	50	50	50
Converted to	20	20	20	20	60	
Marks	Best of CA1 & CA2 Marks(20)		Average of CA3 & CA4 (Marks 20)		60	

### Assessment Methodology

\*L- Listening Skill S – Speaking Skill R – Reading Skill W – Writing Skill.

**Note:**

- CA 1 - 30 Marks [Written Exam from Unit I & II].
- CA 2 - 30 Marks [Written Exam from Unit III, IV & V].
- Marks for Record writing for each exercise is 10 Marks.
- CA 3 -Model Exam (Unit I, II, III, IV & V) – Speaking Skills and Reading Skills.
- CA 4 -Model Exam (Unit I, II, III, IV & V) – Theory, Listening Skills and Writing Skills.
- End Semester Examination: Oral (Speaking and Reading Skills)

**Written** (Theory, Listening Skills and Writing Skills)

- **Selected lists will be provided in the e-Text Book wherever mentioned.**

EN232370	<b>Communicative English – II</b>	L	T	P	C
Practicum		1	0	2	2
<b>Unit I</b>	<b>SITUATIONAL ENGLISH</b>				
<b>Theory: (Prose)</b> Science Fiction Story <b>[Any Short Story with Technical Words]</b> <b>Focus on:</b> a) Technical words <b>[Textual]</b> b) Conversions – Nouns, Verbs, Adjectives and Adverbs using affixes <b>[Textual]</b>		3+6			
<b>PRACTICAL: [Lab/Activity]</b> <b>Exercise: 1</b> <b>Listening:</b> a) Listening to Scientific and Technological Passages. <b>[ Minimum 3 passages]</b> <b>[Conversions - nouns, verbs, adjectives, and adverbs using affixes ]</b> <b>[Minimum 5 conversions from each of the 3 passages]</b> b) One Word Substitution <b>[Technical]</b> <b>[Minimum 5 words from each passage]</b> <b>(To be recorded in the Record Notebook)</b>					
<b>Speaking:</b> a) Process Description – <b>[Making of working models and Lab procedures]</b> b) Situational dialogues <b>[WH, Yes or No]</b>					
<b>Reading:</b> Short Passages Based on Professional Ethics					
<b>Writing:</b> a) Rules for email etiquette b) Email writing – <b>[Business Letters and Job Applications]</b>					
<b>Unit II</b>	<b>FUNCTIONAL ENGLISH</b>				

<p><b>Theory: (Poem)</b>  'The Bangle Sellers' by Sarojini Naidu</p> <p><b>Focus on:</b>       a) Comparison of Adjectives <b>[Textual]</b>                            b) Fill in the blanks with suitable forms of adjectives.<b>[General]</b></p>	
<p><b>Listening:</b>                            Listening to Lyrical Poems and noting down the Descriptive Adjectives.</p>	
<p><b>PRACTICAL: [Lab/Activity]</b></p> <p><b>Exercise: 2</b></p> <p><b>Speaking:</b></p> <p>    a) Word Cloud [ <b>Minimum 3 word clouds</b>]                            <b>[Frame 5 sentences from each Word Cloud]       [Minimum 5 words]</b></p> <p>    b) Homophones and their meanings <b>[General]</b>                            <b>[A selected list of 25 homophones will be provided]</b>                            <b>[To be recorded in the Record Notebook]</b></p>	3+6
<p><b>Reading:</b></p> <p>    a) Reading Comprehension <b>[News Articles]</b>  <b>[Questions and Answers, Synonyms/ Antonyms, Completing the sentence]</b></p> <p>    b) Newspaper Reading Practice is to be given.</p>	
<p><b>Writing:</b></p> <p>    a) Collocations of Technical Words <b>[Match the Collocations]</b>                            <b>[ A selected list of 25 Collocations will be provided]</b></p> <p>    b) Punctuations <b>[Sentences and Passages]</b></p>	
<b>Unit III</b>	<b>EXPRESSIVE ENGLISH</b>
<p><b>Theory: (Prose)</b>       Narrative Essay –                                    'On Saying Please' by A.G. Gardiner</p> <p><b>Focus on:</b>             Reporting Dialogues <b>[Textual/General]</b>                                    <b>[Change into Reported Speech]</b></p>	3+6



<p><b>Listening:</b></p> <p style="text-align: center;">Listen to Scientific Passages <b>[Questions and Answers]</b></p>	
<p><b>Speaking:</b></p> <p style="padding-left: 40px;">a) Facing an Interview Preparations <b>[Checklist]</b> Body Language <b>[Tips]</b></p> <p style="padding-left: 40px;">b) Mock Interviews <b>[Practical Model to be given]</b></p>	
<p><b>PRACTICAL: (Lab/Activity)</b></p> <p><b>Exercise: 3</b></p> <p><b>Reading:</b></p> <p style="padding-left: 40px;">Reading Idiomatic Expressions with their meanings. <b>[Matching the idioms with their meanings]</b> <b>[5 Idioms in each set]</b> <b>[ A selected list of 25 idioms with their meanings will be provided]</b> <b>[To be recorded in the Record Notebook]</b></p>	
<p><b>Writing:</b></p> <p style="padding-left: 40px;">Info graphics/Picture Reading <b>[General/Technical]</b> <b>[Comprehending it as a Paragraph]</b></p>	
<b>Unit IV</b>	<b>EFFECTIVE ENGLISH</b>
<p><b>Theory: (Prose)</b></p> <p>General Prose Passage - <b>[Speech by a famous Indian Personality]</b></p> <p><b>Focus on:</b> Identification of Types of Sentences</p> <p><b>Four Types – Assertive, Interrogative, Imperative and Exclamatory]</b> <b>[Textual/General]</b></p>	3+6
<p><b>Listening:</b></p>	

Speeches of Great Personalities <b>[Note-Taking]</b>		
<b>Speaking:</b> Group Discussion <b>[General Topics – Environmental and Creating Awareness]</b>		
<b>Reading:</b> Reading various types of sentences with intonation <b>[Falling Tone and Rising Tone]</b>		
<b>PRACTICAL: (Lab/Activity)</b> <b>Exercise: 4</b> <b>Writing:</b> Advertisement Writing <b>[Classifieds – Educational, Rental, Real Estate, Automotive, Business Offers] [Minimum one from each classified]</b> <b>[To be recorded in the Record Notebook]</b>		
<b>Unit V</b>	<b>CREATIVE ENGLISH</b>	
<b>Theory:</b> Passages on Motivational Topics <b>Focus on:</b> a) Phrasal Verbs <b>[Textual]</b> b) Framing sentences using Phrasal Verbs <b>[General]</b> <b>[ A selected list of 25 Phrasal Verbs will be provided]</b>		
<b>Listening:</b> Listening to the Weather Reports <b>[Fill up the information gaps]</b>		3+6
<b>PRACTICAL: (Lab/Activity)</b> <b>Exercise: 5</b> <b>Speaking:</b>		

<p>Describing Oneself – <b>[Physical Features, Character Traits, Likes and Dislikes]</b></p> <p><b>[ Describe in points under each aspect ]</b></p> <p><b>[To be recorded in the Record Notebook]</b></p>	
<p><b>Reading:</b></p> <p>Interpreting Graphics into Verbal</p> <p><b>[Pie chart/Bar Diagram/Flow chart]</b></p>	
<p><b>Writing:</b></p> <p>a) Completing a story</p> <p>b) Caption Writing for News Reports</p>	
<b>TOTAL HOURS</b>	<b>45</b>

**INCORPORATE SOME OF THESE DAILY ACTIVITIES IN THE LANGUAGE CLASS**

1. New words and Meanings
2. Proverbs and its Meanings
3. Contextual Vocabulary
4. Frequently Mispronounced Words
5. Cross Word Puzzles (General/Technical)
6. Abbreviations (Social Media)
7. Newspaper Reading Practice

**Suggested List of Student Activities:**

- Presentation/Seminars by students on any recent technological developments based on the branch of study.
- Quizzes are to be conducted based on the course on a weekly/fortnightly basis.
- Role Plays to Practice Speaking and Listening Skills.
- Descriptive Presentations about a specific topic using appropriate vocabulary.
- Language Games like word puzzles, vocabulary quizzes, and interactive games.
- News Discussions to express their opinions on several topics.

- Collaborative writing promotes teamwork which improves writing skills.

**References:**

1. "Cambridge English Skills: Real Listening and Speaking" by Miles Craven
2. "Writing Better English for ESL Learners" by Ed Swick
3. "English Grammar in Use" by Raymond Murphy
4. "Practical English Usage" by Michael Swan
5. "Oxford Basics – Simple Reading Activities" by Jill Hadfield, Charles Hadfield
6. "Oxford Basics – Simple Speaking Activities" by Jill Hadfield, Charles Hadfield

**Web-based/Online Resources:**

1. <https://www.bbc.co.uk/learningenglish/>
2. <https://www.fluentu.com/>
3. <https://www.englishclub.com/>

**COMMUNICATIVE ENGLISH – II (PRACTICUM)**

**ASSESSMENT PATTERN**

**CONTINUOUS ASSESSMENT – I (TOTAL MARKS: 30)**

**Unit I & II (only Theory and Writing Skills)**

- I. Pick out any 5 technical words from the given passage. (5x1=5)  
**[Passage from Science Fiction Short Story – Textual]**
- II. Read the given poetry lines and answer the following questions. (5x1=5)  
**[Poem: 'The Bangle Sellers' – Sarojini Naidu (5 questions)]**
- III. Match the technical words and form corresponding collocations. (5x1=5)  
**[5 words in one set]**
- IV. Correct the paragraph by adding appropriate punctuation and capitalization. **[2 small paragraphs]**  
(2 x 2.5 = 5)
- V. Convert the following words into their corresponding derivatives. (5x1=5)  
**[Textual/General – N/V/Adj/Adv]**
- VI. E-Mail Writing: Business/Job Applications (1x5=5)  
**[Under any one of the mentioned categories]**

**CONTINUOUS ASSESSMENT – II (TOTAL MARKS: 30)**

**Unit III, IV & V (only theory and Writing Skills)**

- I. Choose the correct answer. (Multiple Choice) (5x1=5)  
**[Prose: On Saying Please by A.G. Gardiner - 5 Questions]**
- II. Identify the types of sentences. (5x1=5)  
**[General/Textual –Affirmative, Interrogative (Wh-type and Yes or No type) Imperative and Exclamatory] [5 sentences]**
- III. Frame sentences using the given Phrasal Verbs. (5x1=5)  
**[General/Textual – 5 phrasal verbs]**
- IV. Write a paragraph of 50 words using the given info graphics/picture. (1x5=5)  
**[General/Technical]**

- V. Write classified advertisement – (Educational / Rental / Real Estate / Automotive / Business Offers)  
(1x5=5)

**[Under any one of the specified categories]**

- VI. Write suitable captions for the given news reports: (2x2<sup>1/2</sup>=5)  
**[2 news reports]**

**CONTINUOUS ASSESSMENT – III (TOTAL MARKS: 50)**

**ORAL EXAM - (Speaking Skills and Reading Skills)**

**TEST ON SPEAKING SKILLS (40 marks)**

- I. Describe the process of (Making working models / Lab procedures) (1x10=10)  
**(Under any one of the mentioned categories)**
- II. Describe oneself: (Physical features / Character traits / Likes and dislikes) (1x10=10)  
**(Under any one of the aspects)**
- III. Interpret the given Graphics into Verbal. (Pie chart / Bar Diagram / Flow chart)  
(1x10=10)  
**(Under any one of the mentioned categories)**
- IV. Frame questions using WH and YES or NO type for the given situations. (5x1=5)  
**(5 situations to be given)**
- V. Frame sentences using any 5 words from the given Word cloud. (5x1=5)

**TEST ON READING SKILLS (10 marks)**

- VI. Match the idiomatic expressions with their corresponding meanings. (5x1=5)  
**(5 idiomatic expressions in one set)**
- VII. Read the following sentences with proper intonation. . (5x1=5)  
**(5 sentences - under 4 types of sentences - Affirmative, Interrogative (Wh-type and Yes or No type) Imperative and Exclamatory] [Falling Tone and Rising Tone]**

**CONTINUOUS ASSESSMENT – IV (TOTAL MARKS: 50)**

**WRITTEN EXAM – (Theory, Listening and Writing Skills)**

**TEST ON THEORY PART (15 marks)**

- I. Read the given poetry lines and answer the following questions: **(5x1=5)**  
**[Poem: 'The Bangle Sellers' by Sarojini Naidu – 5 Questions with Poetry lines]**
  
- II. Answer the following short questions in one or two lines: **(5x2=10)**  
**[(Prose: 'On Saying Please' by A.G. Gardiner – 5 Questions)]**

**TEST ON LISTENING SKILLS (5 marks)**

- III. Listen to weather reports and fill in the information gaps. **(2 x 2.5 = 5)**  
**[2 weather reports]**

**TEST ON WRITING SKILLS (30 marks)**

- IV. Fill in the blanks with suitable adjectives. **(5x1=5)**  
**[General - 5 fill-ups with options]**
  
- V. Change the following dialogue into reported speech: **(2 x 2.5 = 5)**  
**[General/Textual – 2 dialogues]**
  
- VI. E-Mail Writing – Business / Job Applications **(1x5=5)**  
**[Under any one of the mentioned categories]**
  
- VII. Write a paragraph of about 50 words using the given info graphics/picture.  
**(1x5=5)**
  
- VIII. Complete the story within 3 to 5 lines and give a title. **(1x5=5)**
  
- IX. Match the technical words and form collocations. **(5x1=5)**  
**[5 words in one set]**

**BOARD EXAMINATION (PRACTICUM)**

**COMMUNICATIVE ENGLISH – II (TOTAL MARKS: 100)**

**(ORAL SKILLS: 50 MARKS + WRITTEN SKILLS: 50)**

**ORAL SKILLS (50 marks)**

**TEST ON SPEAKING SKILL (30 marks)**

- I. Describe oneself: (Physical features / Character traits / Likes and dislikes) **(1x10=10)**  
**(Under any one of the aspects)**
- II. a) Frame questions using **(WH / Yes or No)** for the given situations : **(5x1=5)**  
**(5 Situations to be given)**
- (Or)** **(Or)**
- b) Give the meaning for the set of homophones  
**(2x2<sup>1/2</sup>=5)**  
**(2 homophones in one set)**
- III. Frame sentences using any 5 words in the word cloud. **(5x1=5)**
- IV. Group Discussion: (Environmental / Creating Awareness) **(1x10=10)**  
**(Topics given according to the groups divided)**

**TEST ON READING SKILL (20 marks)**

- V. Interpret the given Graphics into Verbal. (Pie chart / Bar Diagram / Flow chart) **(1x10=10)**  
**(Under any of the mentioned categories)**
- VI. Match the idiomatic expressions with their corresponding meanings. **(5x1=5)**  
**(5 idiomatic expressions in one set)**
- VII. Read the following sentences with proper intonation. **(5x1=5)**  
**(5 sentences - under 4 types of sentences - Affirmative, Interrogative (Wh-type and Yes or No type) Imperative and Exclamatory]**

**WRITTEN SKILLS (50 marks)**

**TEST ON THEORY PART (10 marks)**

- I. Read the poetry lines and answer the following questions: **(4x1=4)**  
**[Poem: 'The Bangle Sellers' by Sarojini Naidu – 4 Questions with Poetry lines]**



- II. Answer the following short questions in one or two lines: **(3x2=6)**  
**[(Prose: 'On Saying Please' by A.G. Gardiner – 3 Questions)]**

**TEST ON LISTENING SKILLS (20 marks)**

- III. Listen to the speech of the **(great personality)** and take down notes.  
**(1x10 =10)**
- IV. Listen to the **(scientific passage)** and answer the following questions:  
**(1x10=10)**

**TEST ON WRITING SKILLS (Any 4) (20 marks)**

- V. Fill in the blanks with suitable adjectives: **(1x5=5)**  
**[General – 5 fill-ups]**
- VI. Frame sentences using phrasal verbs: **(5x1=5)**  
**[5 phrasal verbs]**
- V. E-Mail Writing – Business / Job Applications **(1x5=5)**  
**[Under any one of the mentioned categories]**
- VI. Write a paragraph of about 50 words using the given info graphics/picture.  
**(1x5=5)**
- VII. Match the technical words and form collocations. **(5x1=5)**  
**[5 words in one set]**
- VIII. Write suitable captions for the news reports given: **(2x2.5=5)**  
**[2 news reports]**

ME232120	<b>BASICS OF MECHANICAL ENGINEERING</b>	L	T	P	C
Theory		3	0	0	3

**Introduction:**

Fundamental knowledge in the field of Mechanical Engineering are essential for all engineers. They must thoroughly study the material properties, machine tools and its components before delving into advanced applications. This foundational subject is crucial for a comprehensive grasp of the principles. To develop the necessary psychomotor skills in this area, students should not only understand the concepts but also apply them effectively.

**Course Objectives:**

The objective of this course is to enable the student to

- Understand the essential knowledge and skills of basic Mechanical Engineering encountered in professional practice for diploma holders.
- Comprehend the fundamental concepts and scope of Mechanical Engineering.
- Describe the properties of materials and the variety of machine tools used in the industry.
- Examine the workings and applications of power transmission drives in mechanical systems.
- Identify the various types of engines and power plants to enhance the understanding of their operational efficiencies and energy conversions.

**Course Outcomes:**

On successful completion of this course, the student will be able to

CO1: Recognize the importance of Mechanical Engineering in industrial applications.

CO2: Classify the different types of materials used in metal forming and joining processes.

CO3: Illustrate the principles and industrial applications of lathe, drilling, and milling machines.

CO4: Acquire basic knowledge about power transmission through belt and gear drives.

CO5: Understand the basics of Internal Combustion (IC) Engines and the various types of power plants.

**Pre-requisites:**

Knowledge of basic Science

## CO/PO Mapping

CO / PO	P01	P02	P03	P04	P05	P06	P07
C01	3	2	1	-	-	-	-
C02	1	2	3	-	-	-	1
C03	-	-	3	-	-		1
C04	3	2	2	-	-	-	1
C05	3	2	2	-	-	-	1

Legend: 3-High Correlation, 2-Medium Correlation, 1-Low Correlation

### Instructional Strategy:

- Engage and Motivate: Instructors should actively engage students to boost their learning confidence.
- Real-World Relevance: Incorporate relatable, real-life examples and engineering applications to help students understand and appreciate course concepts.
- Interactive Learning: Utilize demonstrations and plan interactive student activities for an engaging learning experience.
- Application-Based Learning: Employ a theory-demonstrate-practice-activity strategy throughout the course to ensure outcome-driven learning and employability.
- Simulation and Real-World Practice: Conduct demonstrations and hands-on activities in a simulated environment, transitioning to real-world scenarios when possible.
- Encourage Critical Analysis: Foster an environment where students can honestly assess experiment outcomes and analyze potential sources of error in case of discrepancies

### Assessment Methodology

	Continuous Assessment (40 marks)				End Semester Examination (60 marks)
	CA1	CA2	CA3	CA4	
Mode	Written Test (unit 1 & 2)	Written Test (unit 3 & 4)	Quiz / MCQ	Model Examination	Written Examination
Duration	2 hours	2 hours	1 hour	3 hours	3 hours
Exam Marks	60	60	40	100	100
Converted to	20	20	10	10	60
Marks	40				60

**Note:**

- CA1 and CA2 Assessment test should be conducted. Best of one will be considered for the internal assessment of 20 Marks.
- CA3 Online quiz examination (MCQ) should be conducted covering the complete syllabus. The marks should be converted to 10 marks for the internal assessment
- CA4 Model examination should be conducted as per the end semester question pattern. The marks should be converted to 10 marks for the internal assessment.

ME232120	<b>BASICS OF MECHANICAL ENGINEERING</b>	L	T	P	C
Theory		3	0	0	3
<b>Unit I</b>	<b>ROLES AND RESPONSIBILITIES OF MECHANICAL ENGINEERING</b>				
Introduction to Mechanical Engineering-Who is a Mechanical Engineer-Job Description-Roles and Responsibilities-Scope and Opportunities – Mechanical Engineering-Manufacturing-Automobile-PowerGeneration-Maintenance-Service-Design-Quality-Materials Management-Logistics.					9
<b>Unit II</b>	<b>ENGINEERING MATERIALS, METAL FORMING AND JOINING</b>				
<b>Engineering Materials</b> Importance of Materials - Types - Properties: Mechanical - Thermal - Electrical - Magnetic - Chemical - Usages - Applications. <b>Metal Forming</b> Definition – Types – Hot and Cold working – Hot working –Description and working of drop hammer – Rolling – Roll forging – Extrusion – Cold working – Description and working of Mechanical press- Wire drawing <b>Metal Joining</b> Types of Joints – Definitions and Applications: Temporary and Permanent - Examples.					9
<b>Unit III</b>	<b>FUNDAMENTALS OF MACHINE TOOLS</b>				
Machine Tools – Introduction <b>Lathe</b> Principle of Lathe – Description and function of Lathe <b>Drilling Machine</b> Principle of Drilling – Types - Upright Drilling (Description and Function only) <b>Milling Machine</b> Principle of Milling – Horizontal Milling Machine – Vertical milling machine (Description and Function only) <b>CNC</b> Introduction to CNC and its applications					9

<b>Unit IV</b>	<b>POWER TRANSMISSION DRIVES AND LUBRICATION</b>	
	<p><b>Power Transmission Drives</b> Belt drive – Types - Flat, V Belt &amp; Circular or Rope Drive Applications - Applications of chain drive – Gear drives – Types of gear drives – spur gear drive – Helical gear drive – Bevel gear drive – Worm and Worm wheel drive – Rack and pinion drive – Cam Drive - Descriptions.</p> <p><b>Lubrication</b> Lubricants - Types -Solid, Semi Solid, Liquid –Properties of lubricants - Purpose of lubrication –Methods of lubrication - Ring Oiler Lubrication, Drip feed Lubrication and Grease Cup Lubrication.</p>	9
<b>Unit V</b>	<b>FUNDAMENTALS OF HEAT POWER ENGINEERING</b>	
	<p><b>Thermodynamics</b> Definition - Heat - Modes of heat transfer – conduction, convection and radiation (Definition only)</p> <p><b>IC Engines</b> Classification of IC Engines – Working of – Four stroke Petrol Engine – Diesel Engine –Introduction to Battery Electrical Vehicles (BEV)</p> <p><b>Power Plants</b> Power Plants- Introduction to Steam Power plant –Introduction to Nuclear Power plant –Introduction to Solar power plant (PV only) - Introduction to Windmill - Horizontal axis and vertical axis wind mill</p>	9
<b>TOTAL HOURS</b>		<b>45</b>

#### Suggested List of Students Activity:

- Presentation/Seminars by students on any recent technological developments based on the course.
- Periodic class quizzes conducted on a weekly/fortnightly based on the course.
- Mini project that shall be an extension of any practical lab exercise to real-world application.

#### Text Books:

- Fundamentals of Mechanical Engineering / G.S.Sawheny-PHI.
- An Integrated Course in Mechanical Engineering / R.K.Rajput / Biral Publications.
- I.C.Engines / V.GANESAN-TMH.
- Strength of Materials by R.K.Rajput, S.Chand & Company.
- Thermal Engineering / R.K.Rajput / Lakshmi Publications.
- Elements of Workshop Technology - Vol. 1 & 2 - Hajra Choudhury - Media Publishers & Promoters, India.

#### References:

- Thermodynamics and Heat Engines / R .Yadav / Central Book Depot.
- Strength of Materials by R.K.Bansal, Laxmi Publishers.

- Engineering Mechanics Statics and dynamics by A.K.Tayal, Umesh Publication, Delhi.
- Fundamentals of I.C.Engines - P.W.Gill, J.H.Smith & Ziurys - IBH & Oxford pub.
- Workshop Technology Part 1 & Part 2 - W A J Chapman - Cambridge University Press
- A Textbook of Production Engineering - PC Sharma - S Chand

**Web-based/Online Resources:**

- NPTEL (Website): The National Programme on Technology Enhanced Learning (NPTEL) offers free online courses on manufacturing processes and other Mechanical Engineering topics. [NPTEL Mechanical Engineering](#).

<b>CE232120</b>	<b>BASICS OF CIVIL ENGINEERING</b>	L	T	P	C
<b>Theory</b>		3	0	0	3

### Introduction

This course is designed to provide a comprehensive introduction to the field of Civil Engineering, offering fundamental knowledge across various sub-disciplines within this field. It is tailored to meet the educational requirements typically outlined in the syllabus for diploma studies in Engineering. The topics covered are based on the syllabus for diploma studies in Engineering and technology. The contents are arranged in sequence, that starts from the basic concepts and followed in List of materials, Details of materials, Introduction to building planning, Building Construction, Introduction to Surveying, Levelling and Advancements in Civil Engineering.

Throughout this course, students can expect to acquire a solid foundation in civil engineering, providing them with valuable insights into the complexity of industrial projects and the skills required for success in this field. The goal is to equip students with the knowledge and expertise needed to excel in the diverse and challenging world of civil engineering.

### Course Objectives

The objective of this course is to enable the student to

- Introduction to Civil Engineering: Provide students with a fundamental understanding of the field and its significance in various industries and society.
- Foundational Knowledge: Impart essential principles, theories, and concepts in physics, mathematics, and materials science that are pertinent to civil engineering.
- Materials Understanding: Familiarize students with the properties and usage of common construction materials like concrete, steel, and timber.
- Building Planning: Enable students to comprehend architectural plans, designs, and considerations for constructing safe, functional, and aesthetically pleasing buildings.
- Surveying Skills and Levelling Proficiency: Illustrate the basics of land measurement, surveying instruments, and techniques for precise mapping. Provide knowledge and skills related to levelling techniques to ensure accurate elevation measurements in construction projects.
- Awareness of Advancements: Explore emerging technologies and trends in civil engineering, promoting an understanding of the field's ongoing evolution.

### Course Outcomes

After successful completion of this course, the students should be able to	
CO.1	: Describes the uses of different materials in Civil Engineering.
CO.2	: Interpret various aspects of the building planning.
CO.3	: Identify the various building components and methods of constructions.
CO.4	: Illustrate the different equipment for angular and linear measurements.
CO.5	: Describes various public transportation systems, water conservation methods, and advances in civil engineering.

**Pre-requisites : NIL**

**CO/PO Mapping**

CO / PO	P01	P02	P03	P04	P05	P06	P07
C01	3	1	1	1	1	1	3
C02	3	1	1	1	1	1	3
C03	3	1	1	1	1	1	3
C04	3	1	1	2	1	1	3
C05	3	1	1	1	1	1	3

*Legend: 3-High Correlation, 2-Medium Correlation, 1-Low Correlation*

**Instructional Strategy**

- Engage and Motivate: Teachers should actively engage students to boost their learning confidence.
- Real-World Relevance: Teachers are expected to physically show various building materials while imparting instructions. Students should be encouraged to collect sample of various building materials so as to create a museum of materials in the polytechnic.
- Interactive Learning: Teachers are expected to organize demonstrations and field visits to show various stages of construction operations., use of various measurements, instruments in surveying and also train the students to use appropriate instruments to avoid/minimize errors during surveying for better learning experiences.
- Application-Based Learning: Throughout the course, a theory-demonstrate-practice-activity strategy may be used to ensure the outcome of the learning is employability-based.
- Simulation and Real-World Practice: In addition to theoretical instructions, different activities pertaining to the simulated Environment, transitioning to real-world scenarios when possible, like expert lectures, seminars, visits to greenhouse, effluent treatment plant of any industry, rain water harvesting plant etc. may also be organized.
- Encourage Critical Analysis: Foster an environment where students can understand the experiment outcomes and infer the potential sources of error in case of any discrepancies.



## Assessment Methodology

	Continuous Assessment (40 marks)				End Semester Examination (60 marks)
	CA1	CA2	CA3	CA4	
Mode	Written Test (unit 1 & 2)	Written Test (unit 3 & 4)	Quiz / MCQ	Model Examination	Written Examination
Duration	2 hours	2 hours	1 hour	3 hours	3 hours
Exam Marks	60	60	40	100	100
Converted to	20	20	10	10	60
Marks	40				60

### Note:

- CA1 and CA2 Assessment test should be conducted. Best of one will be considered for the internal assessment of 20 Marks.
- CA3 Online quiz examination (MCQ) should be conducted covering the complete syllabus. The marks should be converted to 10 marks for the internal assessment
- CA4 Model examination should be conducted as per the end semester question pattern. The marks should be converted to 10 marks for the internal assessment.

Course Code	Basics of Civil Engineering	L	T	P	C
Program Core			3	0	0
<b>Unit I</b>	<b>INTRODUCTION TO CIVIL ENGINEERING AND CIVIL ENGINEERING MATERIALS</b>				
	Introduction to Civil Engineering – Various disciplines of Civil engineering - Scope, Impact - Role of Civil Engineer - Units of measurement - Unit conversion (Length, Area, Volume) - List of materials, Details (types, properties, uses) of materials: Cement, Aggregate, Brick, Steel, Concrete, Stone, Soil, Mortar, Timber, Plastic, Epoxy, Fly Ash, Steel slag, Copper slag, Bitumen, Optical fiber, Pipe, Wire, Cable and FRP.				10 Hrs
<b>Unit II</b>	<b>INTRODUCTION TO BUILDING PLANNING</b>				
	<p><b>Introduction:</b> Introduction to National Building Code of India 2016 and its parts – Classification of buildings <b>Conventions, Symbols:</b> General – Conventions - Title block- Scales- Line work- Lettering- Symbols-Abbreviations.</p> <p><b>Building Bye-Laws:</b> Objects of bye-laws - Importance of bye-laws- Function of local authority - Setbacks - Plot Coverage - Number of floors - Height of building - Built up Area - Floor space index (FSI) - Views and details necessary for the preparation of a civil engineering drawing.</p> <p><b>Planning of Buildings:</b> Basic requirements, elements - Introduction to various buildings, computation of plinth area, computation of carpet area - Introduction to the types of</p>				10 Hrs

	buildings as per NBC - Selection of site for construction of buildings - Components of a residential building - Requirements - Types of Rooms – Minimum Size requirement for each type of rooms - Introduction to the Industrial buildings - Types - Introduction to the public buildings - Types - General requirements of Public Buildings.	
<b>Unit III</b>	<b>BUILDING CONSTRUCTION</b>	
	<b>Building Construction</b> – Foundations, Classifications - Masonry Works – classifications, definition of different technical terms, Roofs – functional requirements, basic technical terms, roof covering materials, Floors – functions, types, flooring materials (brief discussion), Plastering and Painting – objectives, types.	08 Hrs
<b>Unit IV</b>	<b>INTRODUCTION TO SURVEYING AND LEVELLING</b>	
	Introduction, Conventional systems of measurements, Fundamental principles, Classifications. Linear measurement: Instruments used, Chain Survey on plane ground, Offset, Ranging. <b>Angular measurement:</b> Compass - Instrument used, Meridian, Bearing and Local attraction. <b>Leveling:</b> Instrument used, Terminology, Types of leveling, and Methods of leveling, Introduction to contour survey. <b>Modern tools:</b> Introduction to Theodolite, Total Station, Introduction to Global Positioning System (GPS) and Geographic information system (GIS).	09 Hrs
<b>Unit V</b>	<b>ADVANCEMENTS IN CIVIL ENGINEERING</b>	
	Mass Transportation systems - Bus Rapid Transit System (BRTS), Metro Railway, Solid waste management systems, Rainwater harvesting systems, Smart city and its features, Green buildings, Energy efficient buildings, Heritage structures & its conservations - Descriptions with Sketches only.	08 Hrs
<b>TOTAL HOURS</b>		<b>45 Hrs</b>

#### Suggested List of Students Activities

- Draw the line plan of 1BHK, 2BHK homes.
- Identification, demonstration & prepare sketches of Locally Available building materials
- Prepare Sketches of masonry works.
- Collect the information about modern survey instruments available in the market and prepare the report.
- Visit any one construction site and prepare the construction activity report
- Presentations about any recent technological developments in civil engineering field
- Study the Road, Rail Transportation systems, Rainwater harvesting systems in your city or nearest place and submit the reports
- Conduct class quizzes on a fortnightly basis.
- Prepare Models of any one of the following - Residential building, Commercial, Primary health center, School building
- Micro project that shall be an extension of any practical lab exercise to real-world civil engineering application

#### Reference Books

- S.C. Rangwala, Engineering Material, Charotar Publication.
- S.C. Rangwala. Civil Engineering Drawing, Charotar Publication.
- Gurucharan Singh, Building planning, designing and scheduling, Standard Publisher.
- Dr. B. C. Punamia, Building Construction Publisher: Laxmi Pub. Delhi.
- N. N. Basak, Surveying and leveling, Tata McGraw Hill Education.
- H.S. Peavy, D.R. Rowe and G. Tchbanoglous, Environmental Engineering, McGraw Hill International Edition.

- Khanna S. K. and Justo C. E.G., Highway Engineering, Publisher :Nemchand and Brothers.
- Papacostas C.S., Prevedouros, "Transportation Engineering and Planning, 3 rd Edition, Prentice Hall of India, New Delhi, 2002.
- Vukan R.Vuchie, Urban Transit Systems and Technology, John Wiley and Sons, 2007.
- M.S.Palanichamy, Basic Civil Engineering, McGraw Hill.S. Ramamrutham, Basic Civil Engineering , Dhanpatrai Publication.
- Gkhirasaar, Basic Civil Engineering Dhanpatrai Publication.
- SS Bhavikatti, Introduction to civil engineering, New Age international Publishers.

#### **Web-based/Online Resources**

- <https://nptel.ac.in/courses/105106201>
- <https://nptel.ac.in/courses/105102088/>
- <https://nptel.ac.in/courses/124105013/>
- <http://nptel.ac.in/courses/105107122/>
- <http://nptel.ac.in/courses/105107157/>
- <https://nptel.ac.in/courses/105102015/>
- <http://nptel.ac.in/courses/105101087/>
- <http://nptel.ac.in/courses/105104100/>
- <https://nptel.ac.in/courses/105103205/>
- <https://nptel.ac.in/courses/105102195/>

EE232120	<b>BASICS OF ELECTRICAL AND ELECTRONICS ENGINEERING</b>	L	T	P	C
Theory		3	0	0	3

**Introduction:**

Fundamental knowledge in the field of Electrical and Electronics are essential for all engineers. They must thoroughly study the characteristics of electrical & electronic components before delving into advanced applications. This foundational subject is crucial for a comprehensive grasp of the principles. To develop the necessary psychomotor skills in this area, students should not only understand the concepts but also apply them effectively.

**Course Objectives:**

The objective of this course is to enable the student to

- Understand the fundamental knowledge and skills in basic electrical engineering relevant for diploma holders in their professional life.
- Comprehend the core concepts and an overview of Electrical Engineering for circuit branch specialization.
- Identify the characteristics and uses of semiconductors, PN junction diodes, and Zener diodes, including their symbols.
- Analyze the construction and operation of bipolar junction transistors and their use in electronics.
- Describe the safety protocols, PCB technology, materials, design basics, and essential soldering techniques.

**Course Outcomes:**

After successful completion of this course, the students should be able to

CO1: Analyze the foundational principles of electrical quantities and basic laws for precise calculations in DC circuits with resistors and capacitors.

CO2: Explore different power generation methods and the role of electricity in different job sector.

CO3: Analyze resistors, capacitors, and inductors, including colour coding

CO4: Examine semiconductor properties, doping processes, and diode functions to interpret their electrical characteristics and applications

CO5: Understand the principles of PCB design and the process of soldering electronic components.

**Pre-requisites:**

Knowledge of basic Mathematics and Science

**CO/PO Mapping**

CO / PO	P01	P02	P03	P04	P05	P06	P07
C01	3	2	1	-	-	-	-
C02	1	3	2	-	-	-	-
C03	3	1	-	-	-	-	-
C04	3	2	2	-	-	-	-
C05	3	2	2	-	-	-	-

*Legend: 3-High Correlation, 2-Medium Correlation, 1-Low Correlation*

### Instructional Strategy:

- Engage and Motivate: Instructors should actively engage students to boost their learning confidence.
- Real-World Relevance: Incorporate relatable, real-life examples and engineering applications to help students understand and appreciate course concepts.
- Interactive Learning: Utilize demonstrations and plan interactive student activities for an engaging learning experience.
- Application-Based Learning: Employ a theory-demonstrate-practice-activity strategy throughout the course to ensure outcome-driven learning and employability.
- Simulation and Real-World Practice: Conduct demonstrations and hands-on activities in a simulated environment, transitioning to real-world scenarios when possible.
- Encourage Critical Analysis: Foster an environment where students can honestly assess experiment outcomes and analyze potential sources of error in case of discrepancies.

### Assessment Methodology

	Continuous Assessment (40 marks)				End Semester Examination (60 marks)
	CA1	CA2	CA3	CA4	
Mode	Written Test (unit 1 & 2)	Written Test (unit 3 & 4)	Quiz / MCQ	Model Examination	Written Examination
Duration	2 hours	2 hours	1 hour	3 hours	3 hours
Exam Marks	60	60	40	100	100
Converted to	20	20	10	10	60
Marks	40				60

**Note:**

- CA1 and CA2 Assessment test should be conducted. Best of one will be considered for the internal assessment of 20 Marks.
- CA3 Online quiz examination (MCQ) should be conducted covering the complete syllabus. The marks should be converted to 10 marks for the internal assessment
- CA4 Model examination should be conducted as per the end semester question pattern. The marks should be converted to 10 marks for the internal assessment.

EE232120		<b>BASICS OF ELECTRICAL AND ELECTRONICS ENGINEERING</b>			
Theory					
<b>Unit I</b>	<b>FUNDAMENTALS OF ELECTRICAL ENGINEERING</b>				
<b>Introduction to Electricity</b> – Uses of Electricity in Engineering & Health care - Duties & responsibilities of Electrical Engineer <b>Important Terms :</b> Electrical materials -Electrical quantities- [Charge, Current, Potential difference, DC & AC supply – Types & Difference, Power & Energy] <b>Basic Laws:</b> Coulomb’s law - Lenz Law -Fleming’s rule. <b>Electric Components &amp; Circuits:</b> Simple Voltage, Current, Power & Energy calculation using Series & Parallel connection of Resistors, inductors & Capacitors using Ohm’s law only.					9
<b>Unit II</b>	<b>ELECTRICAL SYSTEMS</b>				
<b>Power generation:</b> Energy sources – Power stations - Block Diagram of AC transmission – Functions of TANGEDCO <b>Conversion of Energy:</b> Motor, Generator and Transformer – main parts, types (names only) and uses. Different types of lamps – Simple lamp circuit - Applications of Solar PV panels – Concept of Electric Vehicles -Types – Domestic house wiring					9
<b>Unit III</b>	<b>PASSIVE COMPONENTS</b>				
Types of Electronic Components - Resistor, Capacitor and inductor - Symbol, Working Principle, Properties, Types and Uses - Colour Coding of Resistor - Self and Mutual Inductance					9
<b>Unit IV</b>	<b>FUNDAMENTALS OF SEMICONDUCTORS</b>				
<b>Semiconductors</b> - Energy Band, Fermi level, Intrinsic and Extrinsic Semiconductors, P-Type and N-Type Semiconductors, Drift Current, Diffusion Current. <b>PN Junction Diode and Zener Diode</b> -Symbol, construction and working- Forward Bias, Reverse Bias, VI Characteristics, Applications.					9
<b>Unit V</b>	<b>ELECTRICAL SAFETY, PCB AND SOLDERING</b>				
<b>Electrical Safety:</b> Hazards of electricity [shock, burns, arc-blast, Thermal Radiation, explosions, fires, effects of electricity on the human body] –Safety precautions - First Aid for Electrical Accidents - Protective devices– Earthing – lightning arrester					9

<b>Introduction to PCB</b> - Types, PCB Materials, Steps involved in preparation of a PCB. <b>Introduction to Soldering</b> - Types of Solder, Soldering Tools, Soldering Safety precautions.	
<b>TOTAL HOURS</b>	<b>45</b>

### Suggested List of Students Activity:

- Presentation/Seminars by students on any recent technological developments based on the course
- Periodic class quizzes conducted on a weekly/fortnightly based on the course
- Micro project that shall be an extension of any practical lab exercise to real-world application
- Electricity Billing for domestic and institutional purposes
- Demonstration of Electrical Components
- Calculating Resistance value by Colour Coding Techniques
- Fabricating PCB for a simple circuit - with 2 or 3 elements

### Text Books

- "Engineering circuit analysis" by W.H. Hayt& J.K. Kemmerly and Steven M. Durbin, , Tata McGraw Hill, 7th edition, New Delhi, 2007
- "Principles of Power Systems" by VK. Metha& Rohit Metha, S. Chand Publishers, 3<sup>rd</sup> Edition, 2005.
- "Electric and Hybrid Vehicles", by A K Babu, Second Edition, Khanna Publishers
- "Electronic Devices and Circuit Theory" by Robert L. Boylestad and Louis Nashelsky
- "Semiconductor Physics and Devices" by Donald A. Neamen
- "Electrical Safety Handbook", by John Cadick, Mary Capelli-Schellpfeffer, Dennis K. Neitzel, Al Winfield, Fourth Edition, The McGraw-Hill Companies, Inc.2012.

### Reference

- "Electric Circuit Analysis", Sudhakar A and Shyam Mohan SP, , Tata McGraw Hill, New Delhi, 2008
- "Electric Circuits" by Mahmood Nahvi, Joseph A Edminister, , Tata McGraw - Hill Education, 5th Edition, 2010
- "Renewables and Efficient Electric Power Systems", Gilbert M. Master, , John Wiley and Sons, 2004.
- "Non-Conventional Sources Of Energy Sources", RAI G D, , KHANNA, 2012
- "Printed Circuit Boards: Design, Fabrication, and Assembly" by Raghbir Khandpur, 2005

### Web-based/Online Resources:

- NPTEL (Website): The National Programme on Technology Enhanced Learning (NPTEL) offers free online courses on semiconductor devices and other electrical engineering topics. [NPTEL Electrical Engineering](#)
- Electronics Hub (Website): Offers tutorials and articles on PCB design, soldering techniques, and electronics projects. [Electronics Hub](#)

<b>CS232120</b>	<b>BASICS OF COMPUTER ENGINEERING</b>	L	T	P	C
<b>Theory</b>		3	0	0	3

**Introduction:**

Understanding the basic components and working of a computer gives more freedom for the learners to explore and innovate. The knowledge about the various hardware and software devices will help the learners to choose the devices according to the needs. The ability to differentiate the types of software is essential in the career of a computer engineer. This course will inculcate the much-needed essential information about the computers in the minds of young engineers.

**Course Objectives:**

The objective of this course is to enable the student to

- Comprehend the basics of computer organization.
- Investigate various input and output devices.
- Classify the different storage devices.
- Identify the types of software.
- Grasp the concept of the World Wide Web.

**Course Outcomes:**

After successful completion of this course, the students should be able to

CO1: Remember the basic organization of computers.

CO2: Distinguish between the various input and output devices.

CO3: Examine the different storage devices.

CO4: Describe the types of software.

CO5: Identify the concept of the internet and security issues related to internet use.

**Pre-requisites:**

Nil

**CO/PO Mapping:**

CO / PO	P01	P02	P03	P04	P05	P06	P07
<b>C01</b>	3	3	3	-	-	3	1
<b>C02</b>	3	3	3	-	-	3	2
<b>C03</b>	3	3	3	-	-	3	1



<b>C04</b>	3	3	3	-	-	3	2
<b>C05</b>	3	3	3	-	-	3	2

Legend: 3-High Correlation, 2-Medium Correlation, 1-Low Correlation

### Instructional Strategy

- Engage and Motivate: Instructors should actively engage students to boost their learning confidence.
- Real-World Relevance: Incorporate relatable, real-life examples and engineering applications to help students understand and appreciate course concepts.
- Interactive Learning: Utilize demonstrations and plan interactive student activities for an engaging learning experience.
- Application-Based Learning: Employ a theory-demonstrate-practice-activity strategy throughout the course to ensure outcome-driven learning and employability.
- Simulation and Real-World Practice: Conduct demonstrations and hands-on activities in a simulated environment, transitioning to real-world scenarios when possible.
- Encourage Critical Analysis: Foster an environment where students can honestly assess experiment outcomes and analyze potential sources of error in case of discrepancies.

### Assessment Methodology

	Continuous Assessment (40 marks)				End Semester Examination (60 marks)
	CA1	CA2	CA3	CA4	
Mode	Written Test (unit 1 & 2)	Written Test (unit 3 & 4)	Quiz / MCQ	Model Examination	Written Examination
Duration	2 hours	2 hours	1 hour	3 hours	3 hours
Exam Marks	60	60	40	100	100
Converted to	20	20	10	10	60
Marks	40				60

### Note:

- CA1 and CA2 Assessment test should be conducted. Best of one will be considered for the internal assessment of 20 Marks.
- CA3 Online quiz examination (MCQ) should be conducted covering the complete syllabus. The marks should be converted to 10 marks for the internal assessment
- CA4 Model examination should be conducted as per the end semester question pattern. The marks should be converted to 10 marks for the internal assessment.

CS232120		L	T	P	C
Theory	<b>BASICS OF COMPUTER ENGINEERING</b>	3	0	0	3
<b>Unit I</b>	<b>INTRODUCTION TO COMPUTERS</b>				
	Introduction – Characteristics of Computers – Evolution of Computers - Data, Information and Program - Basic Computer organization - Central Processing Unit, Processor Speed, Arithmetic and Logic Unit (ALU), Memory Unit, Input and Output Unit.				<b>8</b>
<b>Unit II</b>	<b>INPUT DEVICES AND OUTPUT DEVICES</b>				
	Introduction to Input Devices – Keyboard - Scanner - Microphone – Mouse (Optical Mouse, Mechanical Mouse), Touch Screen, Web Camera, Wearable Devices - Computer Output Fundamentals – Printers (Laser Printer, 3D Printers) – Monitors (Liquid Crystal Display, Light Emitting Diodes) - Projector – Speaker – Computer Cables (HDMI, VGA, USB, PS/2, Ethernet, 3.5mm jack).				<b>10</b>
<b>Unit III</b>	<b>COMPUTER MEMORY AND STORAGE</b>				
	Introduction - Bits and Bytes – Memory Hierarchy - Primary Memory – Random Access Memory (RAM) – Read Only Memory (ROM) - Secondary Memory – Secondary Storage Devices – Hard Disk, Optical Disks, Flash Drive, Solid State Drives (SSD) – Cache Memory.				<b>10</b>
<b>Unit IV</b>	<b>COMPUTER SOFTWARE</b>				
	Computer Software –Types of Software – System Software: Compilers, Linker, Loader, Operating Systems (Windows, Linux Basics) – Application Software: Word Processors, Presentation Software, Graphics Software - Difference between Program and Packages – Introduction to Python Programming - Real Time Applications of Software: ERP, Finance.				<b>10</b>
<b>Unit V</b>	<b>INTERNET AND SECURITY</b>				
	Concept of Internet - Applications of Internet - Popular Web Browsing Software – Search Engines – Computer Ethics –Social Networks and E-Commerce - Cloud Computing Basics - Security Issues Over the Internet – Introduction to Cyber Security.				<b>7</b>

#### Suggested List of Students Activity:

- Presentation/Seminars by students on any recent technological developments based on the course.
- Periodic class/online quizzes conducted based on the course.
- Blended learning activities to explore the recent trends and developments in the field.

#### References:

- Tamilnadu SCERT, Chapters 1-5, 17, Introduction to Computers, Number Systems, Computer Organization, Theoretical Concepts of Operating System, Working with Windows Operating System, Computer Ethics and Cyber Security, Computer Science, Class XI, 2022.
- NCERT, Chapter 1-3: Computer System, Encoding Scheme and Number Systems, Emerging Trends, Class XI, 2023.
- Tamilnadu SCERT, Chapter 15, Introduction to Internet and Email, Class XI, Computer Technology, 2019.
- Tamilnadu SCERT, Chapter 15, E-Commerce, Class XII, Computer Applications, 2022.
- Computer Programming and IT, Ashok N. Kamthane, Raj Kamal, Pearson India, 2012, ISBN: 9788131774694
- Computer Ethics Etiquette and Safety (for the 21st century student), Nancy E. Wilfred, Viva Books Private Limited 2009. ISBN-13 : 978-8130909042
- Cloud Computing, A. Srinivasan, Pearson India, 2014, ISBN: 9789332537439

**Web-based/Online Resources:**

- CPU Speed : <https://www.intel.com/content/www/us/en/gaming/resources/cpu-clock-speed.html>
- Types of Computer Cable Connections : <https://www.buildcomputers.net/computer-cable-connections.html>
- Social Network: <https://www.britannica.com/technology/social-network>

DP232370	<b>DRAFTING PRACTICES</b>	L	T	P	C
PRACTICAL		0	0	4	2

**Introduction:**

Engineering drawing is the language of engineers. By means of drawing, the shape, size, finish, colour, and construction of any object can be described accurately and clearly. Hence, drawing is a way for communicating engineer's ideas, designs, and thoughts to others. It is necessary for the engineers to develop their skill in preparing engineering drawings. This subject is planned to include sufficient practices which would help the student in visualization of two-dimensional objects and developing the drawing skills. Nowadays, Computer Aided Drafting (CAD) practices are used invariably in all the industries to create drawings easily and quickly. Hence this subject is aimed to acquire basic knowledge in manual drafting as well as in CAD. The chapters are arranged in sequence and starts from the basic concepts of lettering, dimensioning, geometrical constructions, construction of polygon and department specific drawings.

**Course Objectives:**

The objective of this course is to enable the student to

- List the usage of various drawing instruments.
- Understand the basics of lettering and dimensioning of drawings.
- Acquire the ability to draw the basic geometrical constructions.
- Understand the basics of CAD.
- Use CAD in designing and developing department specific drawings.

**Course Outcomes (CO):**

On successful completion of this course, the student will be able to

- CO1 : Utilize various drawing instruments to create manual drawing.
- CO2 : Construct the drawings as per BIS
- CO3 : Build the basic geometrical constructions
- CO4 : Create department specific drawings using various commands in CAD.

**Pre-requisites:** NIL

**CO/PO Mapping**

CO / PO	P01	P02	P03	P04	P05	P06	P07
C01	3	2	1	-	-	-	-
C02	2	3	2	-	-	-	-
C03	2	1	3	-	-	-	-
C04	-	-	-	3	-	-	-

C05	-	-	-	-	-	-	-
-----	---	---	---	---	---	---	---

Legend: 3-High Correlation, 2-Medium Correlation, 1-Low Correlation

#### Instructional Strategy:

- ◆ **Engage and Motivate:** Instructors should actively engage students to boost their learning confidence.
- ◆ **Real-World Relevance:** Incorporate relatable, real-life examples and engineering applications to help students understand and appreciate course concepts.
- ◆ **Interactive Learning:** Utilize demonstrations and plan interactive student activities for an engaging learning experience.
- ◆ **Application-Based Learning:** Employ a theory-demonstrate-practice-activity strategy throughout the course to ensure outcome-driven learning and employability.
- ◆ **Simulation and Real-World Practice:** Conduct demonstrations and hands-on activities in a simulated environment, transitioning to real-world scenarios when possible.
- ◆ **Encourage Critical Analysis:** Foster an environment where students can honestly assess experiment outcomes and analyze potential sources of error in case of discrepancies.

#### Assessment Methodology

	Continuous Assessment (40 marks)				End Semester Examination (60 marks)
	CA1	CA2	CA3	CA4	
Mode	Manual Drafting (Unit – I)	Manual Drafting (Unit – II)	Model Exam	Practices and Record of Work done	Practical Examination
Duration	2 hours	2 hours	3 hours	-	3 hours
Exam Marks	60	60	100	100	100
Converted to	10	10	10	10	60
<b>Marks</b>	<b>40</b>				<b>60</b>

#### Note :

- 1) CA1 : Three questions should be given from Unit – I to draw in the drawing sheet and the same should be evaluated for 60 Marks. Each question carries 20 Marks.
- 2) CA2 : Three questions should be given from Unit – II to draw in the drawing sheet and the same should be evaluated for 60 Marks. Each question carries 20 Marks.
- 3) CA3 : Model Examination for 100 Marks.
- 4) CA4 : All exercises [4 Drawing sheets (each 5 marks) + 8 CAD Drawings (each 10 marks)]. The same should be submitted for the board examination as a record of work done.

DP232360	<b>DRAFTING PRACTICES</b>	L	T	P	C
PRACTICAL		0	0	4	2

**COMMON TO ALL BRANCHES**

<b>PART – A : MANUAL DRAFTING</b>					
<b>[Note : The drawings (Ex.Nos.1 – 4) should be drawn in drawing sheets and the same should be submitted for evaluation]</b>					
Unit – I	<b>BASICS OF DRAWING AND DIMENSIONING</b>				
Importance of engineering drawing - drawing practice as per BIS code - drawing instruments: drawing board, mini drafter, drawing sheets, drawing pencils, set squares, etc.					4
<b>Lettering and numbering</b> as per BIS - single stroke letters - uppercase and lowercase letters.					
<b>Dimensioning</b> – need for dimensioning - terms and notations as per BIS - parallel, chain and progressive dimensioning.					
Ex.No.1. (a) Rewrite the given statement in a single stroke vertical uppercase letters (5 statements) (b) Rewrite the given statement in a single stroke vertical lowercase letters (5 statements)					4
Ex.No.2. Redraw the given drawing and dimension it as per BIS. (Fig.1 – Fig.4)					6
Unit – II	<b>GEOMETRIC CONSTRUCTION AND CONSTRUCTION OF POLYGONS</b>				
<b>Geometric Constructions</b> : Bisect a straight line, an arc and an angle – divide a straight line and circle into a number of equal divisions – construct an arc touching two straight lines at any angle – construct an arc touching two arcs.					4
<b>Construction of Polygons</b> : Triangle, square, rectangle, pentagon and hexagon – various positions – side of the polygon is parallel, perpendicular and inclined to principal planes.					
Ex.No.3. (a) Divide a straight line and circle into given number of equal divisions (b) Construct an arc touching two straight lines (c) Construct an arc touching two arcs					
Ex.No.4. Construct the polygon of given size (Choose any suitable method) (Triangle, Rectangle, Square, Pentagon and Hexagon)					4
<b>PART – B : COMPUTER AIDED DRAFTING</b>					
<b>[Note : The drawings (Fig.1 – Fig.8) should be created using CAD Software and the printout should be submitted for evaluation]</b>					
Unit – III	<b>BASICS OF COMPUTER AIDED DRAFTING (CAD)</b>				
<b>Introduction to CAD</b> – applications – advantages of CAD over manual drafting – understanding user interface – types of coordinate systems - absolute, relative, polar – drafting settings – Limits – Units – Creating objects using draw commands – Line, Arc, Circle, Rectangle, Ellipse, Polygon, Point, Pline, Sketch – Creating text – Dtext, Mtext, Text styles – Mline, spline – Drawing with precision – Osnap options – drawing aids – Fill, Snap, Grid, Ortho lines – Function keys – Editing and modify commands – Object selection methods – Erasing object – Oops – Canceling and undoing a command – Copy – Move – Array – Offset – Scale – Rotate – Mirror – Break – Trim – Extend – Explode – Divide –					8

Measure – Stretch – Lengthen – Changing properties – Color, Line types, LT scale – Matching properties – Editing with grips – Pedit – Ddedit – Mledit.	
Basic dimensioning – Editing dimensions – Dimension styles – Adding leaders – Creation of blocks – Wblock – Inserting a block – Block attributes – Hatching – Pattern types – Boundary hatch – Working with layers – View group commands – Zoom, redraw, regen, pan – Enquiry tools.	
Page setup in layout – Viewports – Plotting drawings.	
Ex.No.5. Draw the given drawing and dimension it as per BIS using CAD (Fig.1 – Fig.4)	6

#### FOR MECHANICAL ENGINEERING AND ALLIED COURSES ONLY

Unit – IV	ORTHOGRAPHIC VIEWS USING CAD	
<b>Orthographic projections</b> – planes of projection – principal orthographic views – first angle projection – third angle projection – Construction of orthographic views of simple components using CAD.		4
Ex.No.6. Draw the orthographic views of the given component using CAD (Fig.5 – Fig.8)		8

#### FOR CIVIL ENGINEERING AND ALLIED COURSES ONLY

Unit – IV	BASIC CIVIL ENGINEERING DRAWINGS USING CAD	
Important terminologies used in Civil Engineering Drawing – Basic conventional symbols – materials, doors, windows, stairs, walls, sanitary fittings, etc. – Basic civil engineering drawing using CAD.		4
Ex.No.6. Draw the given civil engineering drawing using CAD (Fig.5 – Fig.8) (a) Cross sectional view of L -section, T-section, Channel and I - Section (b) Plan, Elevation and Sectional view of a Single storey, Single room consisting of RCC Flat Roof, Masonry walls, Lintel cum Sunshade, Door and windows of standard size. (c) Floor plan of a 2BHK residential building. (d) Plan and Sectional Elevation of a RCC Column with square isolated footings.		8

#### FOR EEE AND ALLIED COURSES ONLY

Unit – IV	BASIC ELECTRICAL WIRING CIRCUITS USING CAD	
<b>Basic electrical symbols</b> - fuse, main switch, electrical bell, earth, SPST, DPST, TPST, Neutral link, ammeter, voltmeter, wattmeter, energy meter, frequency meter, power factor meter, timer, buzzer, MCB, etc. – Drawing of basic electrical circuits diagrams using CAD.		4
Ex.No.6. Draw the given electric circuit diagram using CAD. (Fig.5 – Fig.8) (a) Stair-case wiring electric circuit (b) Control and main circuit of automatic star delta starter (c) Control circuit for jogging in cage induction motor (d) Single phase wiring circuit		8

**FOR ECE, COMPUTER ENGINEERING AND ALLIED COURSES ONLY**

<b>Unit – IV</b>		<b>BASIC ELECTRONICS CIRCUITS USING CAD</b>
<b>Basic electronics symbols</b> - Resistor, Capacitor, Inductor, PN Junction Diode, Zener Diode, BJT, JFET, MOSFET, GND and VCC, Transformer, Switch, Buzzer, Battery, etc. Drawing of basic electronics circuits diagram using CAD.	4	
Ex.No.6. Draw the given electronics circuit diagram using CAD. (Fig.5 – Fig.8) (a) Half Wave Rectifier circuit (b) Bridge Rectifier circuit (c) Common Emitter Amplifier circuit (d) Fire Alarm circuit	8	
<b>Continuous Assessment Test &amp; Revision</b>		8
<b>Total Periods</b>		<b>60</b>

**Note :** Suitable drawings should be provided to students for Ex.Nos.2, 5 & 6

**Suggested List of Students Activity:**

- ◆ Download and learn the BIS Codes for various engineering practices.
- ◆ Prepare 3D models of drawings with the help of cardboard to visualize and understand the orthographic views.
- ◆ Presentation/Seminars by students on any recent technological developments based on the course
- ◆ Periodic class quizzes conducted on a weekly/fortnightly based on the course
- ◆ Mini project that shall be an extension of any practical lab exercise to real-world application

**Text Books:**

1. Bhatt N.D. and Panchal V.M., "Engineering Drawing", Charotar Publishing House, 53 Edition, 2019.
2. Natrajan K.V., "A Text Book of Engineering Graphics", Dhanalakshmi Publishers, Chennai, 2018.
3. T. Jayapoovan, "Engineering Drawing & Graphics Using Autocad", Vikas Publishing House Pvt. Ltd.
4. M. Yogesh, B. S. Nagaraja, N. Nandan, "Computer Aided Electrical Drawing", PHI Learning Pvt. Ltd.
5. Thomas Tumilty, "AutoCAD for Electronics", PHI Learning Pvt. Ltd.

**Reference:**

1. Basant Agrawal, Agrawal C M "Engineering Drawing", McGraw hill HED
2. Venugopal.K, Prabhu Raja V, "Engineering Graphics", New Age International Publishers.
3. Mark Dix, Paul Riley, "Fundamentals of AutoCAD" PHI Learning Pvt. Ltd.
4. BL Theraja, AK Theraja, "A Textbook of Electrical Technology", S. Chand & Company Ltd.
5. D Chattopadhyay, PC Rakshit, "Fundamentals of Electric Circuit Theory", S. Chand & Company Ltd.
6. R. S. Sedha, "A Textbook of Electronic Circuits", S. Chand & Company Ltd.

**Web-based / Online Resources:**

- ◆ <https://www.autodesk.in/campaigns/autocad-tutorials>
- ◆ <https://www.mycadsite.com/tutorials.html>



## BOARD EXAMINATIONS

### Allocation of Marks

Description	Marks
<b>Part – A : Short Answer Questions</b>	
25 One mark Questions from Unit – I, II & III (25 x 1 = 25 Marks)	25
<b>Part – B : Computer Aided Drafting</b>	
1) Drawing & Dimensioning using CAD from Unit – III Any <b>one</b> drawing out of four drawings (1 x 25 = 25 Marks)	25
2) Department specific drawing using CAD from Unit – IV Any <b>one</b> drawing out of four drawings (1 x 45 = 45 Marks)	45
<b>Viva – voce</b>	5
<b>Total Marks</b>	<b>100</b>

**DRAWINGS FOR LAB EXERCISES**

**COMMON FOR ALL BRANCHES**

*(All dimensions are in mm)*

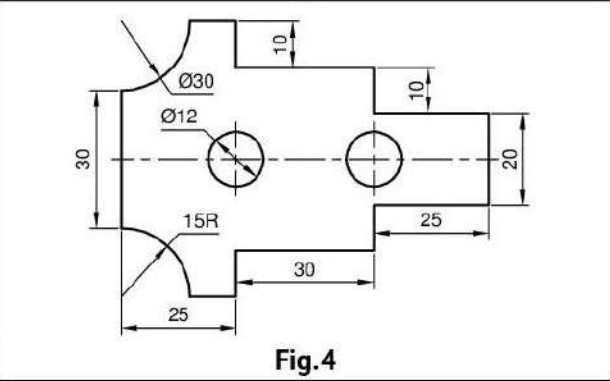
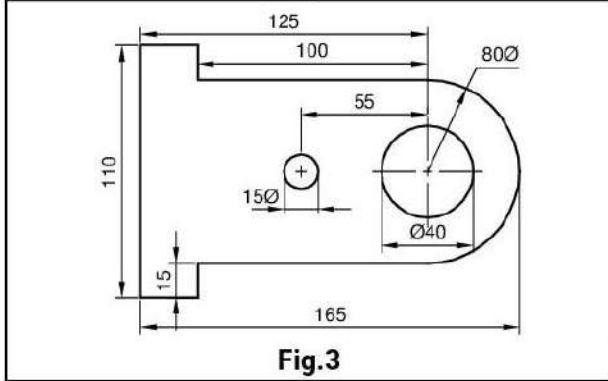
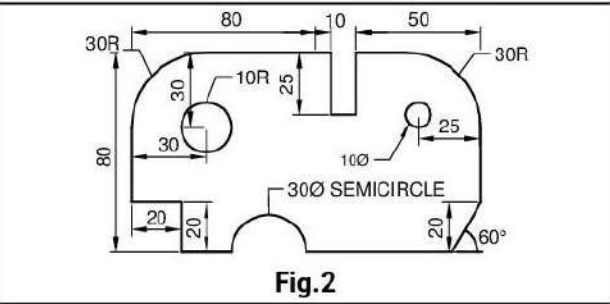
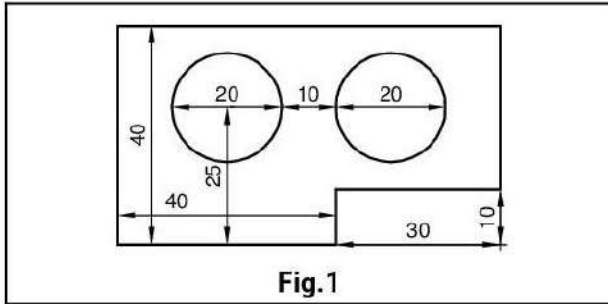

**FOR MECHANICAL ENGINEERING AND ALLIED COURSES ONLY**

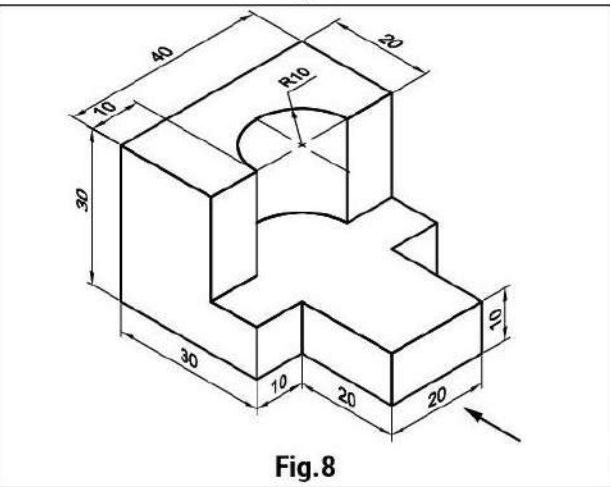
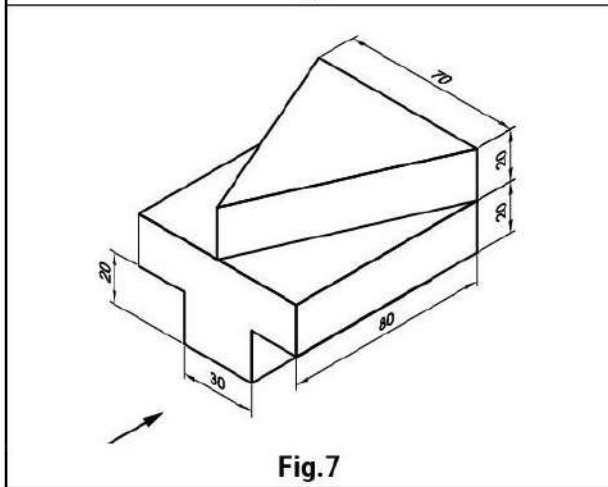
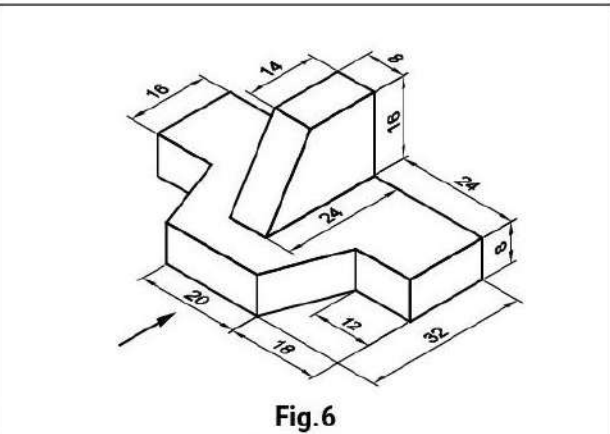
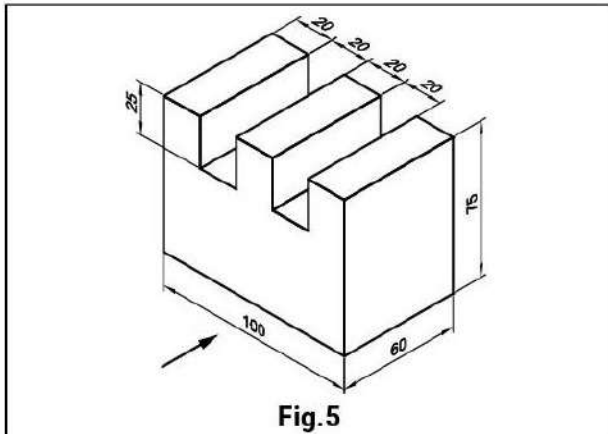

**FOR CIVIL ENGINEERING AND ALLIED COURSES ONLY**

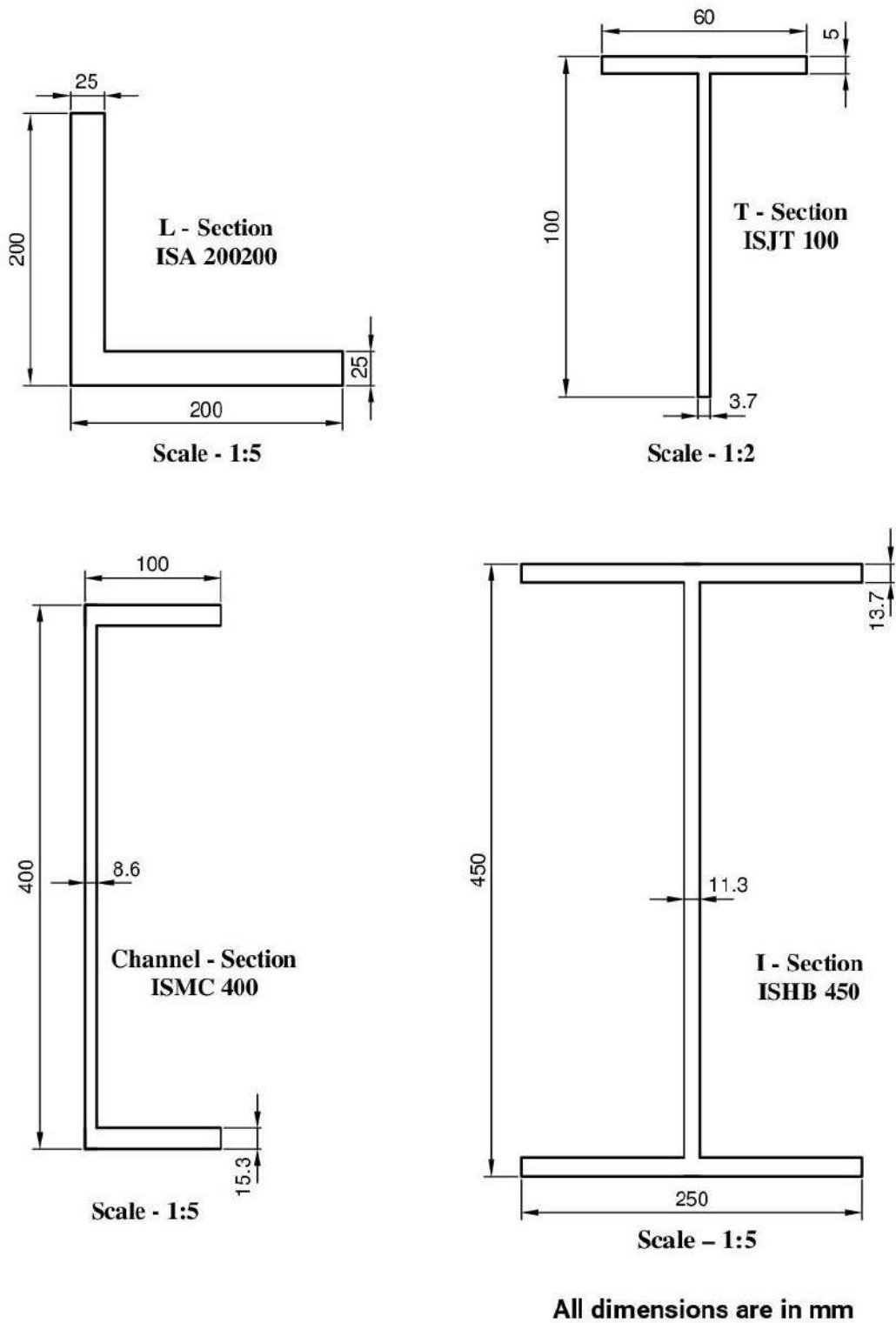

**Fig.5. Cross sectional view of L -section, T-section, Channel section and I- Section**

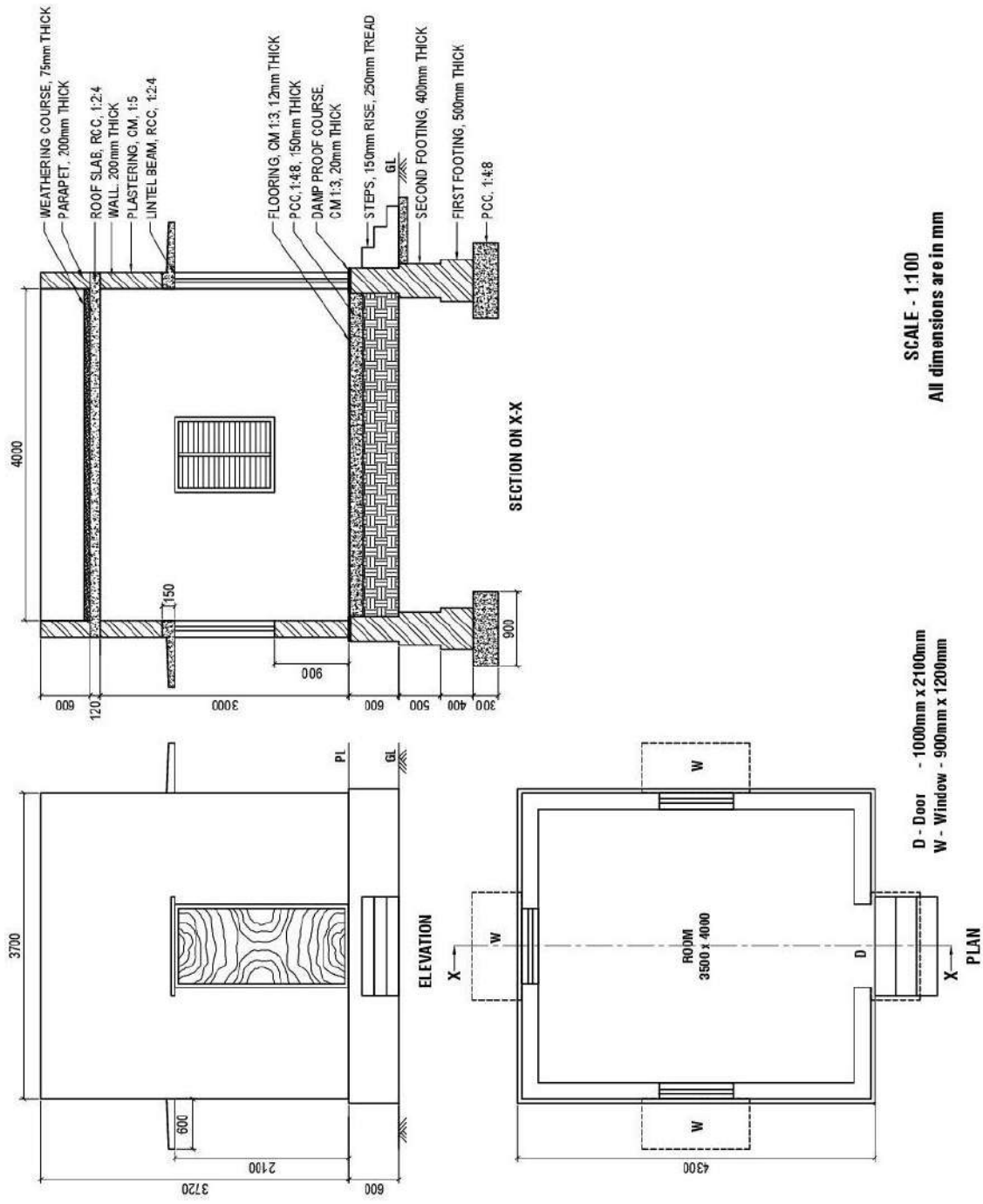

**Fig.6. Plan, Elevation and Sectional view of a single storey building with single room**

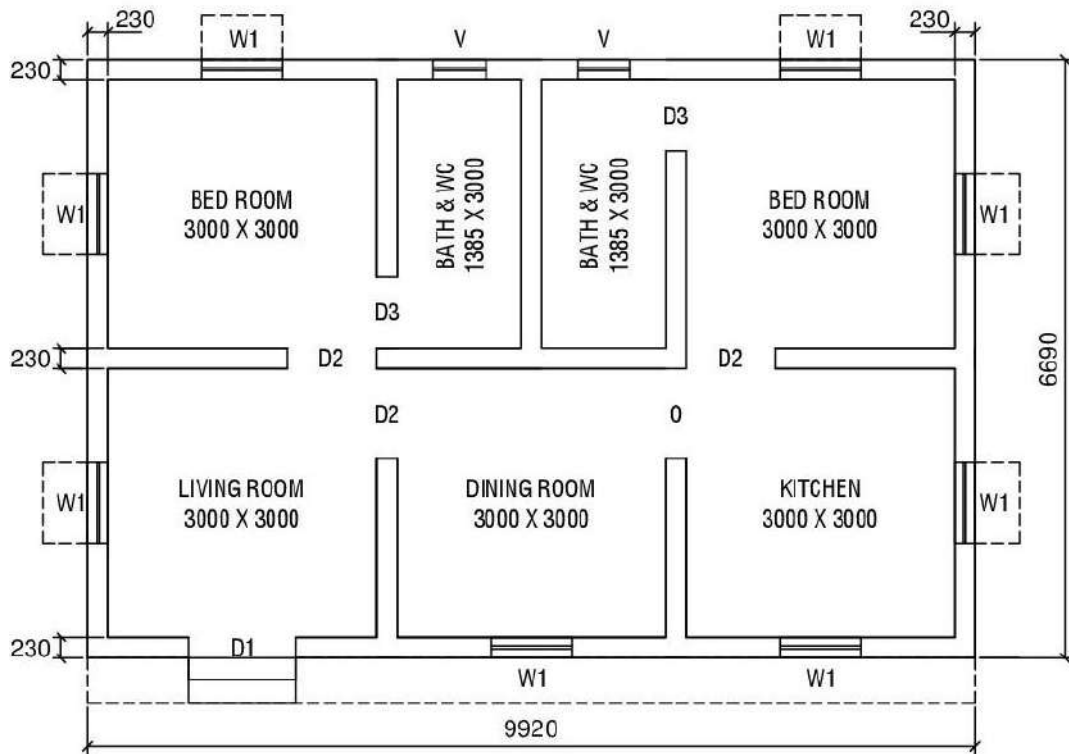

Window (W) - 900 mm x 1200 mm    Door (D1) - 1200 mm x 2100 mm  
 Ventilator (V) - 600 mm x 600 mm    Door (D2) - 1000 mm x 2100 mm  
 Door (D3) - 800 mm x 2100 mm

**SCALE - 1:100**  
**All dimensions are in mm**

**Fig.7. Floor plan of 2 BHK residential building**

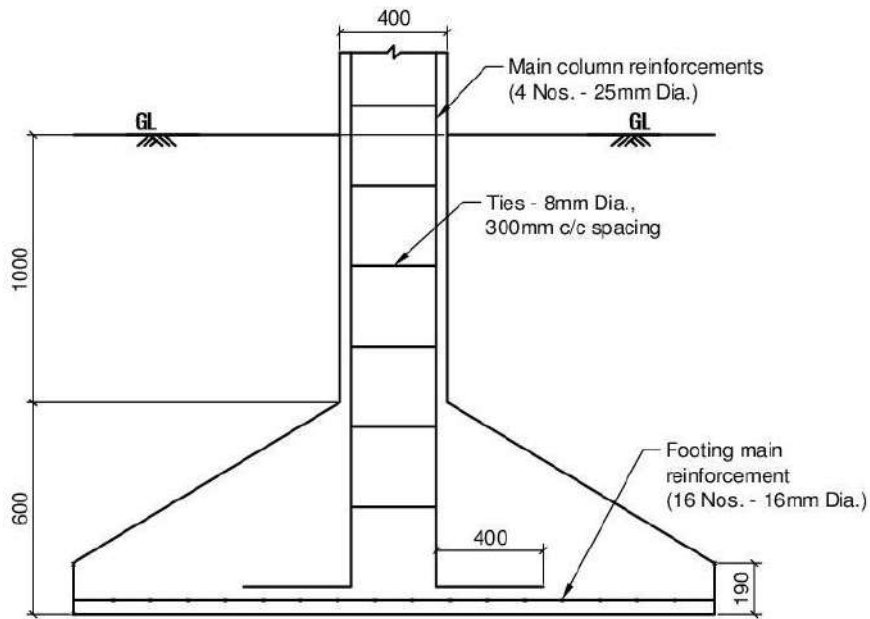

**SECTIONAL ELEVATION OF COLUMN AND FOOTINGS**

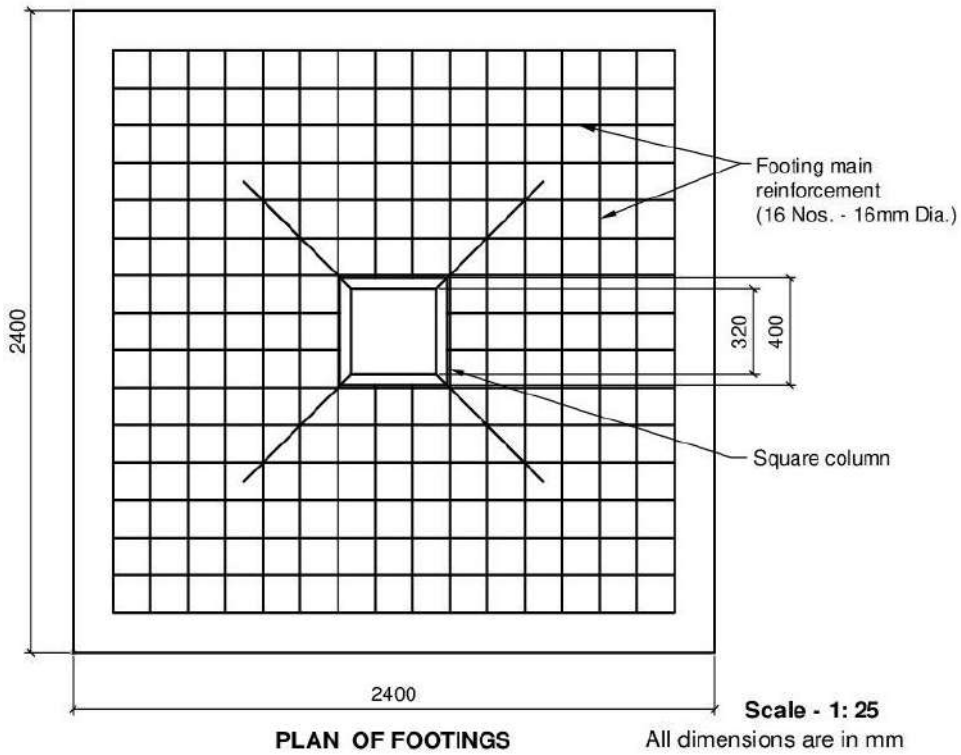

**PLAN OF FOOTINGS**

Scale - 1: 25  
All dimensions are in mm

**Fig.8 RCC column with square isolated footing**

**FOR EEE AND ALLIED COURSES ONLY**

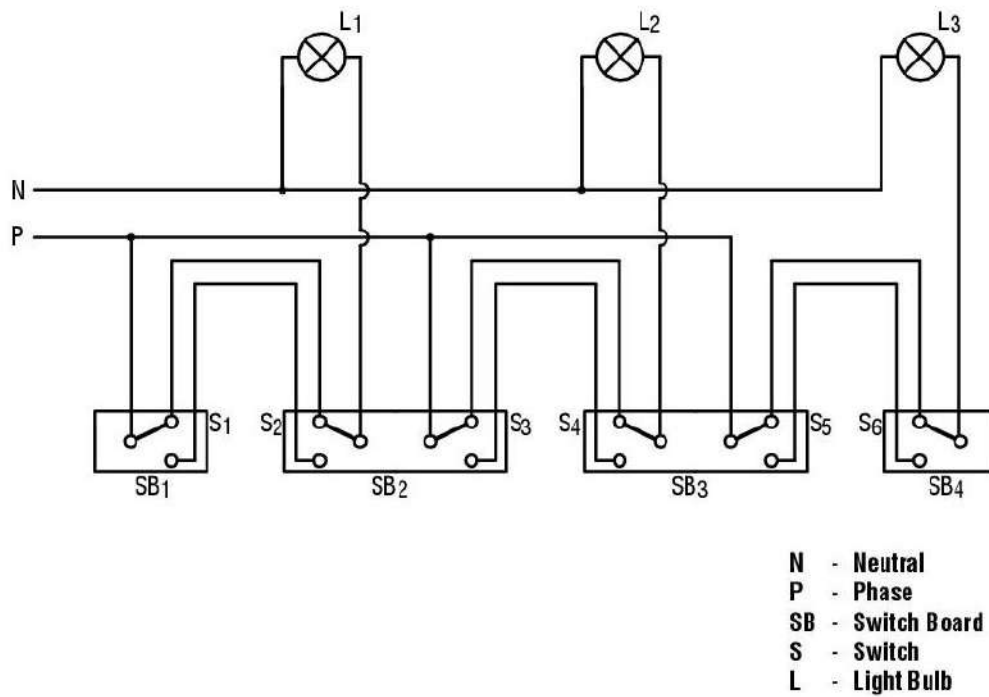

**Fig.5. Staircase wiring electric circuit**

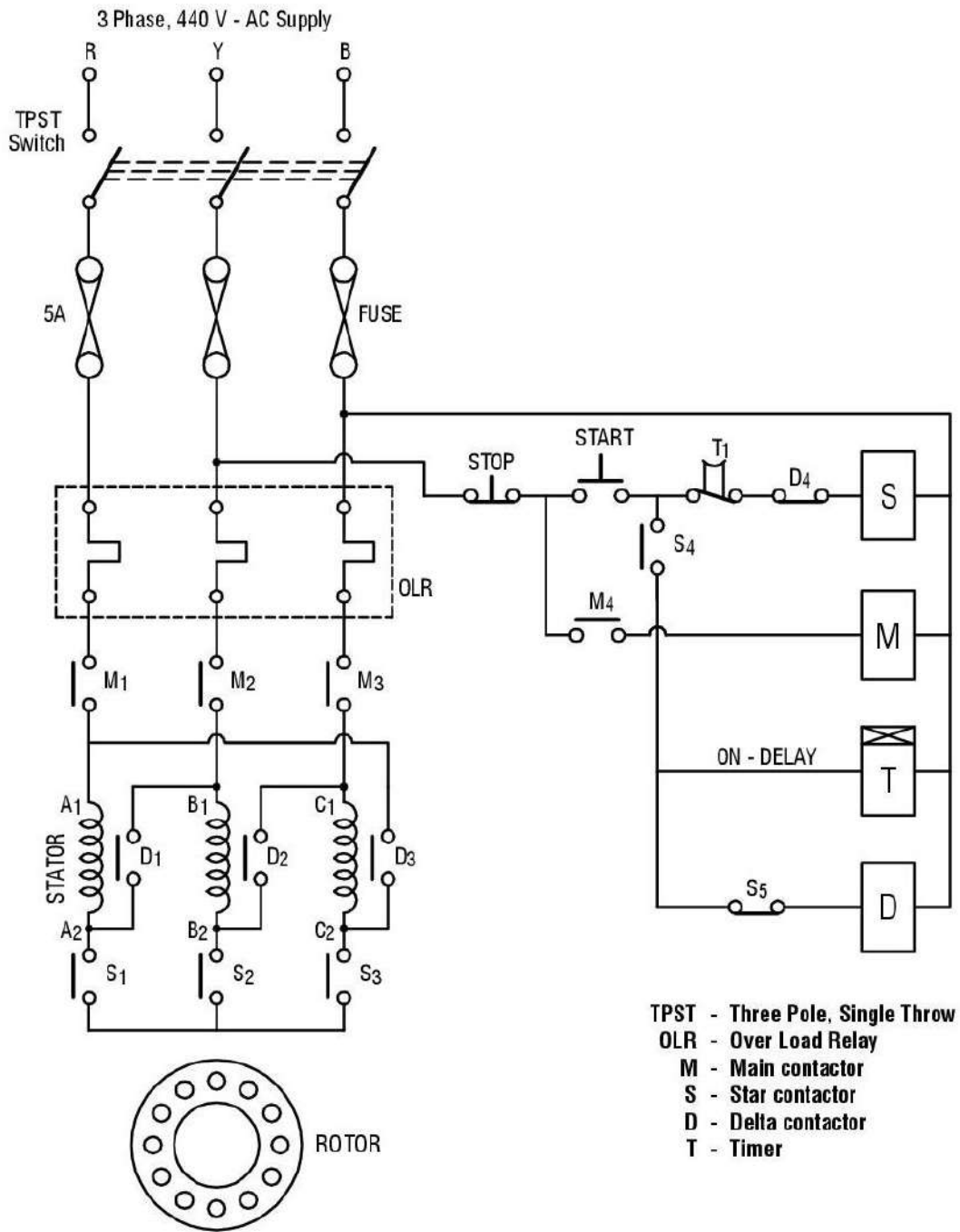
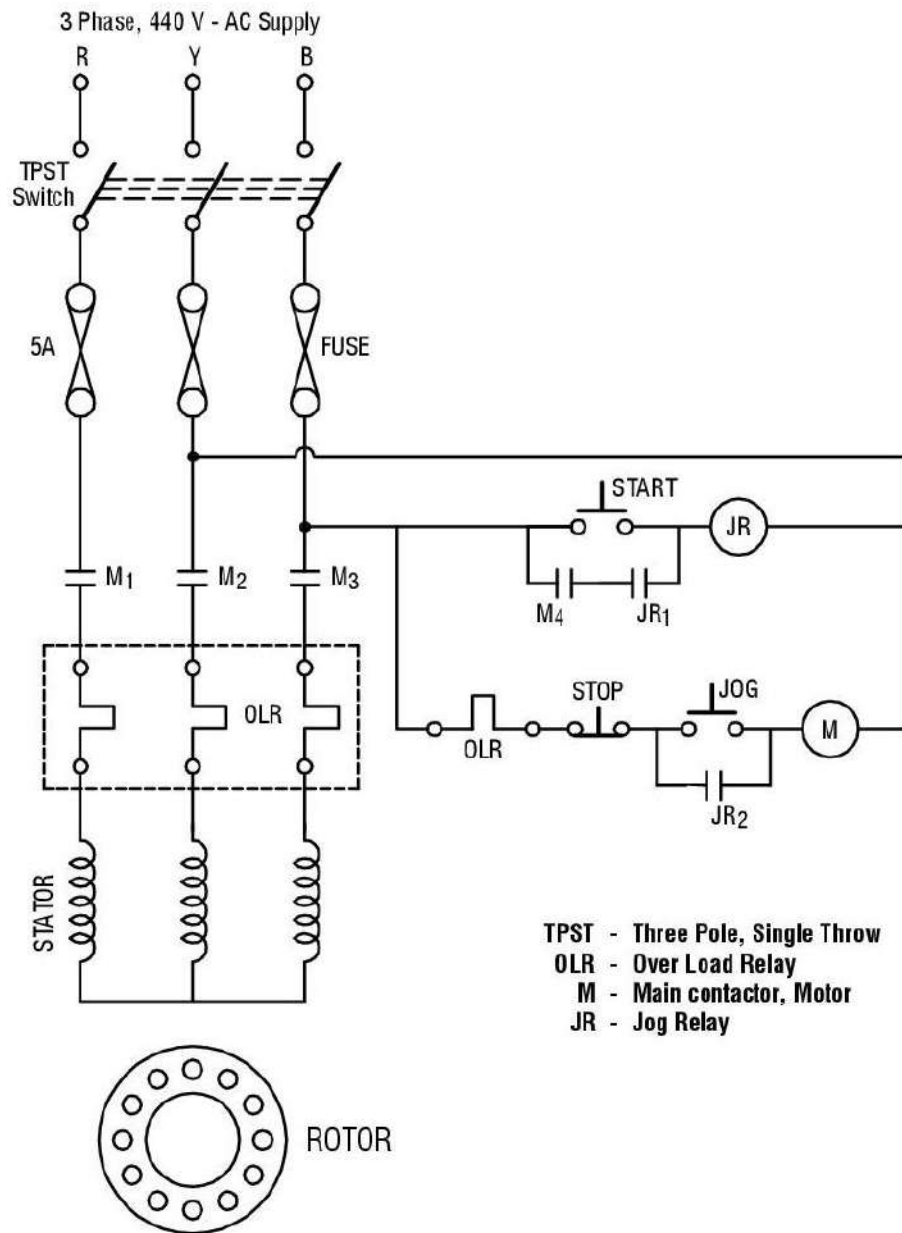
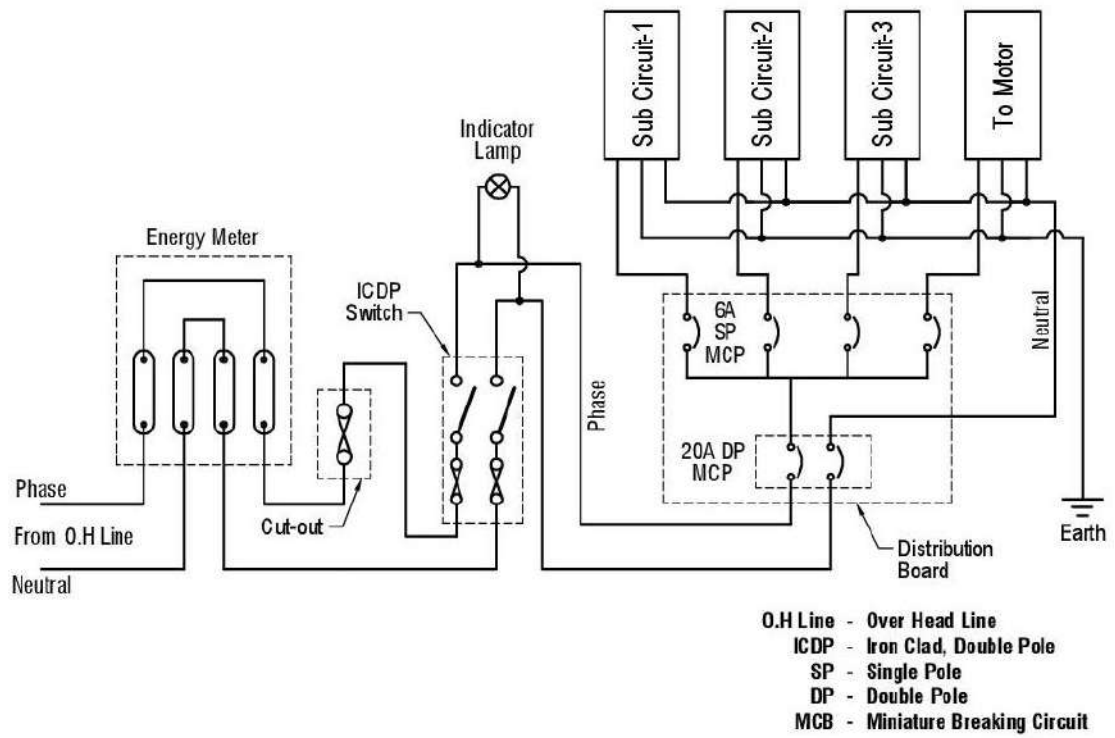

Fig.6. Control and main circuit for automatic star delta starter

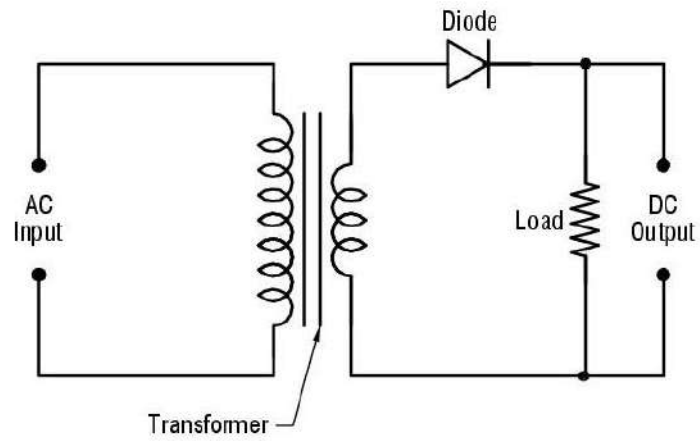



**Fig.7. Control circuit for jogging in cage induction motor**



**Fig.8. Single phase wiring circuit**



**Fig.5. Half wave rectifier circuit**

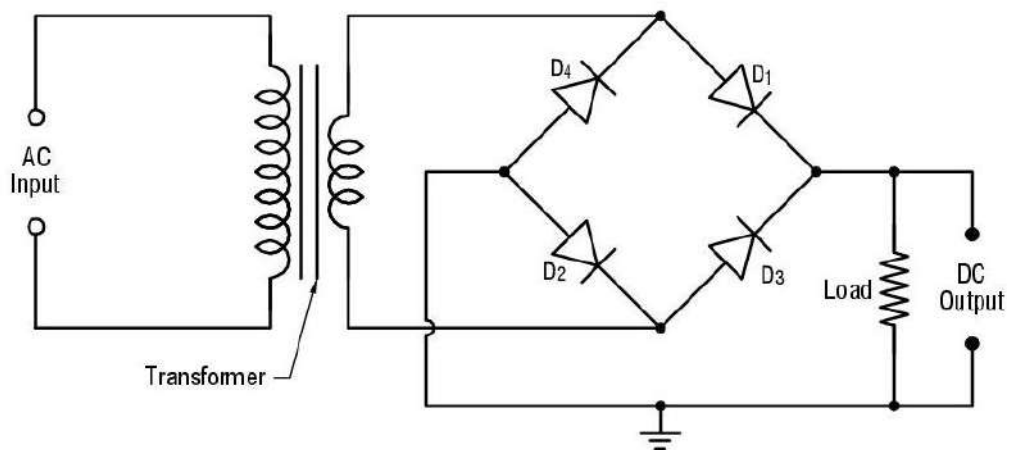

**Fig.6. Bridge rectifier circuit**

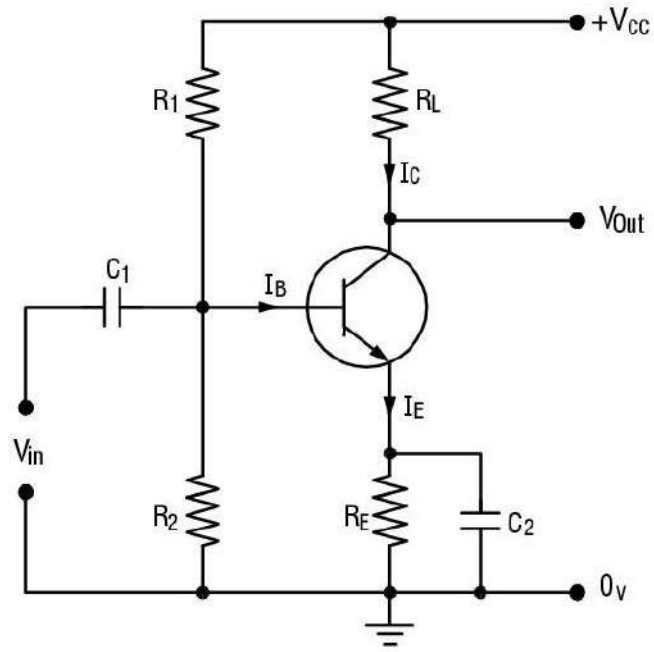

**Fig.7. Common emitter amplifier circuit**

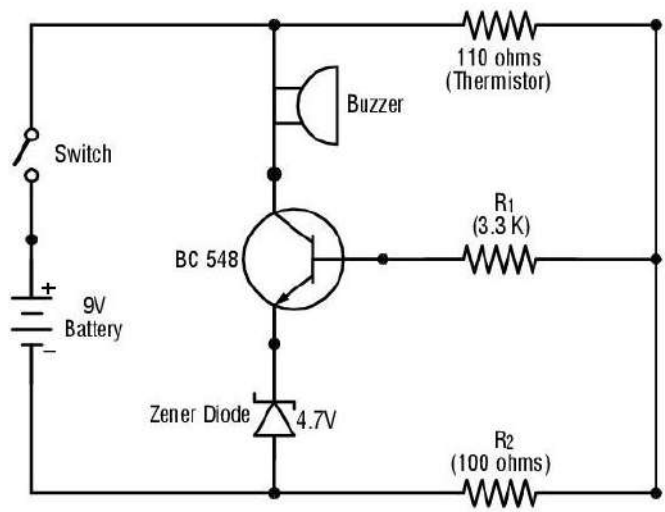

**Fig.8. Fire alarm circuit**

<b>EP232460</b>	<b>BASIC ENGINEERING PRACTICES</b>	<b>L</b>	<b>T</b>	<b>P</b>	<b>C</b>
<b>Practical</b>		<b>1</b>	<b>0</b>	<b>2</b>	<b>2</b>

### **Introduction**

It has been realized that Tamil Nadu would become a prosperous and a modern state by rising skill levels. It is very much important for fresh technicians to be highly skilled in dealing with the modern technologies in the Mechanical, Electrical, Plumbing and Safety & Security system works of building since the building systems have become more integrated. Besides, having the onsite experience is valid to build up quality craftsmanship.

By understanding the huge demand of the skilled technicians in the basic engineering practices. This course equips participants with the knowledge and skills needed to install water supply and drainage systems, guarantee water quality, Low Voltage power supply installation, and safety & security systems.

### **Course Objectives**

The objective of this course is to prepare the student,

- To understand the work area and piping materials and tools for plumbing.
- To install the water supply system, drainage system, pipes, sanitary fixtures and pipe fittings.
- To install a water pump and to operate and maintain a water purifier unit.
- To perform the basic distribution of electrical supply and installation of electrical fixtures for domestic applications.
- To study and connect the basic security and safety systems.
- To learn about the fire fighting extinguisher and fire fighting systems.

### **Course Outcomes**

On successful completion of this course, the student will be able to,

CO1: Execute the installation of assembled pipes, fittings, and other components for water supply and drainage systems.

CO2: Establish the installation of pipes, fittings, and other components for drainage systems.

CO3: Learn and Install the water pump and water purifier.

CO4: Affix electrical fixtures and implement Lightning Arrester and Earthing Systems for Low Voltage System.

CO5: Install the safety and security system.

### Pre-requisites

NIL

### CO/PO Mapping

CO / PO	P01	P02	P03	P04	P05	P06	P07
CO1	3	3	2	1	1	1	2
CO2	3	3	2	1	1	1	2
CO3	3	3	2	1	1	1	2
CO4	3	3	2	1	1	1	2
CO5	3	3	2	1	1	1	2

Legend: 3-High Correlation, 2-Medium Correlation, 1-Low Correlation

### Instructional Strategy

- It is advised that teachers take steps to pique pupils' attention and boost their curiosity to learn.

- Implement task-based learning activities where students work on specific tasks or projects.
- Incorporate technology tools and resources, such as online platforms, interactive multimedia, and virtual communication tools, to enhance engagement and provide additional practice opportunities.
- Incorporate formative and summative assessments to gauge student progress and provide targeted feedback.
- Throughout the course, a theory-demonstrate-practice-activity strategy may be used to ensure that learning is outcome and employability based.
- All demonstrations/Hand-on practices may be followed in the real environment as far as possible.

### Assessment Methodology

	Continuous Assessment (40 marks)				End Semester Examination (60 marks)
	CA1	CA2	CA3	CA4	
Mode	Practical (Exercises 1,2,5 and 6)	Practical (Exercises 3,4,7 and 8)	Model Practical (All Exercises)	Record of work done (8 Exercises + 2 Reports)	Practical Examination
Duration	2	2	3	-	3
Exam Marks	80	80	100	100	100
Converted to	15	15	15	10	60
Marks	15		15	10	60

Note:

CA1 and CA2: It should be conducted as per the end semester question pattern for 80 Marks (without written test). The 80 marks will be converted to 15 Marks. The best one will be considered for the Internal Assessment of 15 Marks.

CA 3: After completion of all the exercises, model examination should be conducted as per end semester question pattern. The mark should be converted to 15 Marks for the internal assessment.

CA 4: Record of work done should be maintained and the same have to be evaluated after completion of each practical exercise before the commencement of the next exercise for 10 Marks. Two activity reports should be completed and the same should be evaluated for 10 marks each. The average of 8 practical exercises and 2 reports marks should be converted to 10 Marks for the internal assessment.



EP232460	BASIC ENGINEERING PRACTICES	L	T	P	C
Practical		1	0	2	2
	<p>Plumbing - Sanitary Work - Safety during work - Types of plumbing pipes - Plumbing tools - Cutting Tools - Plumbing Symbols - Pipe Fittings - Types of pipe joints - Pipe bending tools - Pipe Cutting - Threading a Pipe - Methods of Testing Pipelines - Smoke Test - Pressure Hydraulic Test - Plumbing and Sanitary Fixtures - Tap or Faucet - Shower - Water Closets - Flushing Cistern - Geysers - Valves.</p> <p>Types of Pumps - Deep Well Pump - Centrifugal Pump - Reciprocating Pump - Jet Well Pump - Rotary Pump - Water Meter. Causes of Damage to the Pipeline and Plumbing System - Steps for Repair - defects commonly encountered in the functioning of taps and faucets, its causes and remedial measures - The defects commonly encountered during the functioning of stopcock, its causes and remedial measures - The commonly encountered defects during the operation of gate valves, their causes and remedial measures.</p> <p>Types of water purifiers - Reverse Osmosis (RO) water purifiers - Ultra Filter water purifiers - Ultraviolet (UV) Water Purifiers - Gravity Based water purifiers - Activated Carbon water purifiers - Guidelines for Installation of Water Purifier - Identify the Fault - Common problems and their solutions.</p>	5			
Exercise 1	Install the water supply system as shown in the layout (shower with hot and cold water supply) and prepare the bill of material with specifications.	3			
Exercise 2	Install the drainage system as shown in the layout and prepare the bill of material with specifications.	3			
Exercise 3	Install the given pump for the water supply to storage. Prepare the list of components with specifications.	3			
Exercise 4	Install the Water Purifier and mount the filter. Demonstrate how to replace the damaged components, membrane, filter, valve and water tank.	3			

	<p>Basic Concept of Electricity - Types of electricity - Voltage - Current - Classification of current - Resistance - Electric power - Power factor - Basic Electric Circuit - Series Circuit - Parallel Circuit - Ohm's Law - Kirchhoff's Law - Power - Energy - Tools and Equipment - Importance of Earthing System - Types of Earthing - Pipe Earthing - Plate Earthing - Lightning - Lightning Arrester - Wiring materials - Insulating Materials - Wiring Accessories - Miniature Circuit Breaker (MCB) - Conduit Wiring - Concealed Wiring - Colour Code - Distribution Board - Electrical Hazard - Fire Extinguisher - First Aid for Electrical Emergencies - Electrical Rescue Techniques.</p> <p>Different Types of CCTV Cameras - Components Needed for CCTV Camera Installation - IP Camera Installation - Security Cameras - Best Locations for Indoor and Outdoor Camera - Installing Network Video Recorders (NVR) for CCTV Systems - Configuring and Testing the CCTV Systems - Maintenance and Troubleshooting of CCTV Camera Systems - Tips for Mounting Cameras Safely.</p> <p>Fire Alarm System Components - Alarm Signalling Systems - Automatic Alarm-Initiating Devices - Manually Actuated Alarm-Initiating Devices - Inspection and Testing / Smoke Detector using Arduino and Smoke Sensor: Components used - Arduino UNO development board - 16x2 LCD - Smoke Sensor - Breadboard - Connecting wires. - Fire alarm - Installation procedure.</p>	6
Exercise 5	Connect the single phase power supply for domestic applications as per the circuit diagram. List the bill of materials with specifications.	3
Exercise 6	Prepare an earth bit and erect the earth electrode / plate. Mention the importance of Earthing and Lightning arrester.	3
Exercise 7	Install a CCTV camera and configure. Mention the list of components.	3
Exercise 8	Install the Smoke Detector Alarm / Fire alarm system as per the circuit. (Electrical / IOT based)	3
	Assessment test	10
	<b>Total Hours</b>	<b>45</b>

**Suggested list of student activity** (The hours allotted for General revision and test can be used to prepare the report)

1. Study the existing water supply / drainage system / water recycling plant and prepare the report.
2. Study the existing water treatment plant and prepare the report.
3. Study the existing CCTV system and prepare the report.
4. Study the existing fire fighting system and prepare the report.

**Note:** Four students can be grouped as a batch to prepare and submit the activity report. Each batch should submit any two reports from the above activity. The report should have the layout of the system, bill of materials with specifications and important common troubles/errors and rectification procedure.

**Reference:**

- Multi Skill Technician (Electrical) QP Code: ELE/Q3115.
- Plumber Practical (I Year) - Neelkanth, English NSQF Level - 3 ITI Book.
- Plumber Theory Manish Sharma.
- Plumber Trade Practical NIMI, Chennai.
- Craftsmen Training Scheme (CTS) NSQF Level-3 Central Staff Training and Research Institute, Kolkata.
- IoT Based Smart Home Automation and Energy Management.
- Multi Skill Technician (Electrical) ELE/Q3109 v1.0.
- Jal Vitaran Sanchaalak (Water Distribution Operator) (Multi - Skill) PSC/Q0122.
- Selection, Installation and Maintenance of First-Aid Fire Extinguishers – Code of Practice ( Third Revision )
- CCTV Camera Equipment Installation, Service & Maintenance.
- CCTV Camera installation Book Mr.Prabhu, Prabhu and Manikanda Prabhu
- CCTV Surveillance: A CCTV security system training book Kindle Edition by M. J. Ansari.
- Selection, Installation and Maintenance of Control and indicating equipment for fire detection and alarm system - Code of practice.

### **Web-based/Online Resources**

Major Water Supply Schemes | TWAD (tn.gov.in)

Deposit Works | TWAD (tn.gov.in)

Rural Water Supply Schemes | TWAD (tn.gov.in)

Urban Water Supply Schemes | TWAD (tn.gov.in)

Under Ground Sewerage Schemes | TWAD (tn.gov.in)

<https://youtu.be/OTI9iSGIObU>

[https://youtu.be/FBu\\_DU-hK04](https://youtu.be/FBu_DU-hK04)

<https://youtu.be/xNrZ1uZS8uU>

<https://youtu.be/Hyjr44BcazA>

<https://youtu.be/JAiwJP7l3ko>

<https://youtu.be/kDg-0DbVsxQ>

<https://youtu.be/2bCLDM74F2k>

<https://youtu.be/obkUNBH1xnY>

<https://youtu.be/USajjGYjUH4>

<https://youtu.be/UrWgV1F7JFs>

<https://youtu.be/Y8duhoCdDz4>

[https://youtu.be/GUml\\_IH9cAc](https://youtu.be/GUml_IH9cAc)

<https://youtu.be/JWXh-Wwqlwl>

### **Additional Instructions**

Note: For the record of work done for practical exercises, a notebook or printed manual may be used. In this, the student should draw a diagram, and mention the readings/observations, calculations and result manually. The same has to be submitted for the end-semester examination on the first attempt.

The proper safety procedure and norms should be followed with proper uniform (Khaki pants & half-hand shirt) with safety shoes during the practices.

All the exercises should be completed before the Board Practical Examinations. Students will be permitted to select any one exercise by lot or the question paper provided by the DOTE.

### Allocation of Marks for End Semester Examinations.

Part	Description	Marks
A	Layout / Circuit	10
B	List of Tools / Equipments and Materials	10
C	Procedure / Observation / Installation	30
D	Finish / Completion	20
E	Written test (MCQ question) *	20
F	Viva voce	10
	Total	100

#### Written test (MCQ)

Twenty one mark MCQ questions shall be asked from the theory portions.

#### Sample diagram / Layout for Practical Exercises.

The following diagrams are suggestions for the practical exercise not limited to this. The practical exercises should have minimum practices to learn and meet the course outcome.

**Exercise 1 – Water supply system**

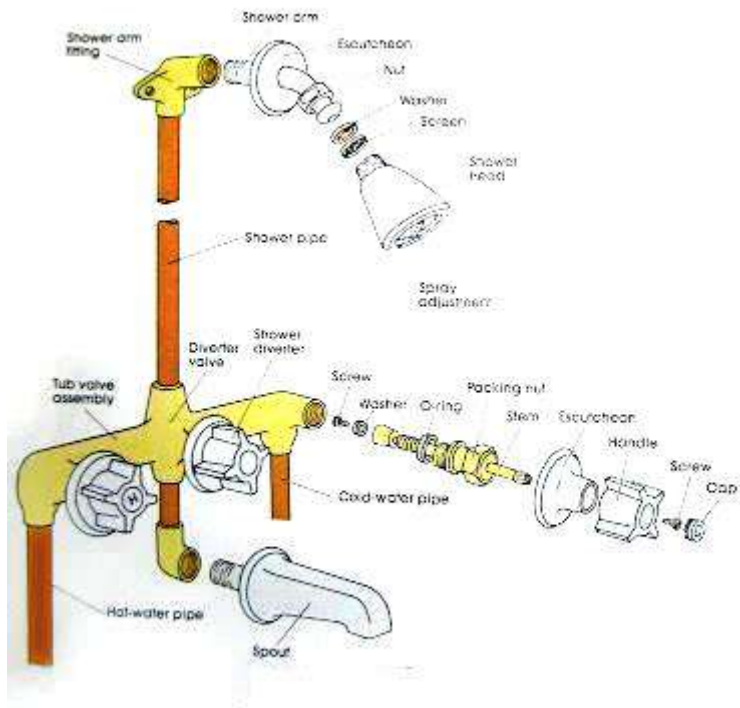
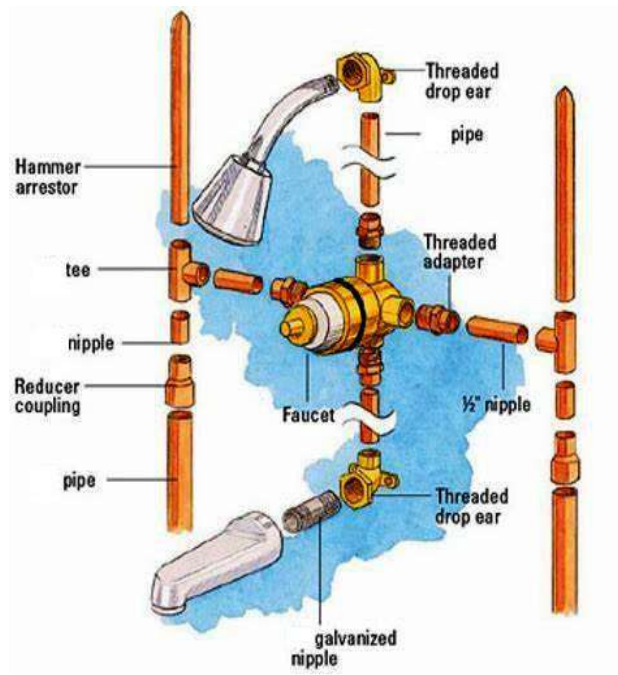
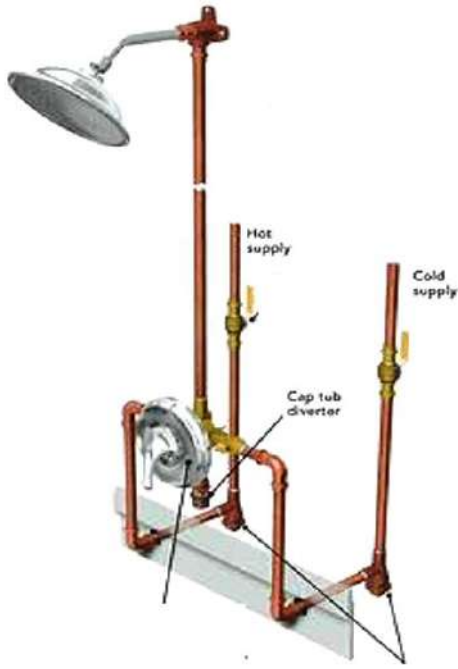

**Exercise 2 – Drainage System**

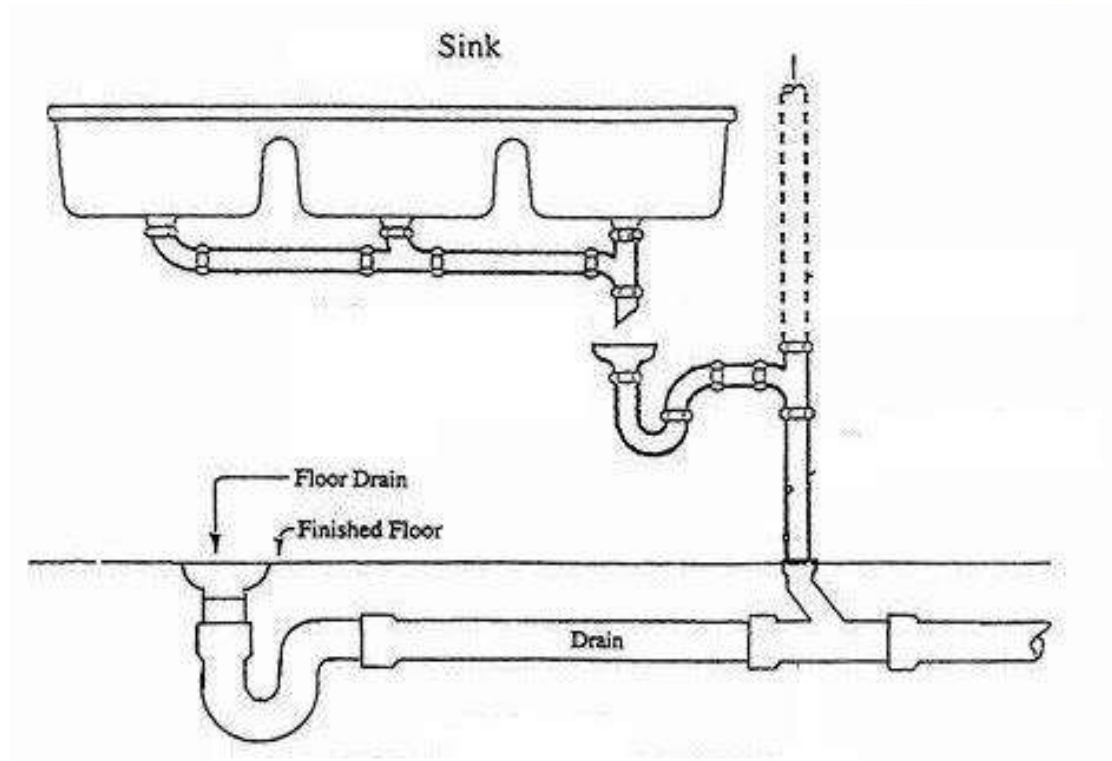
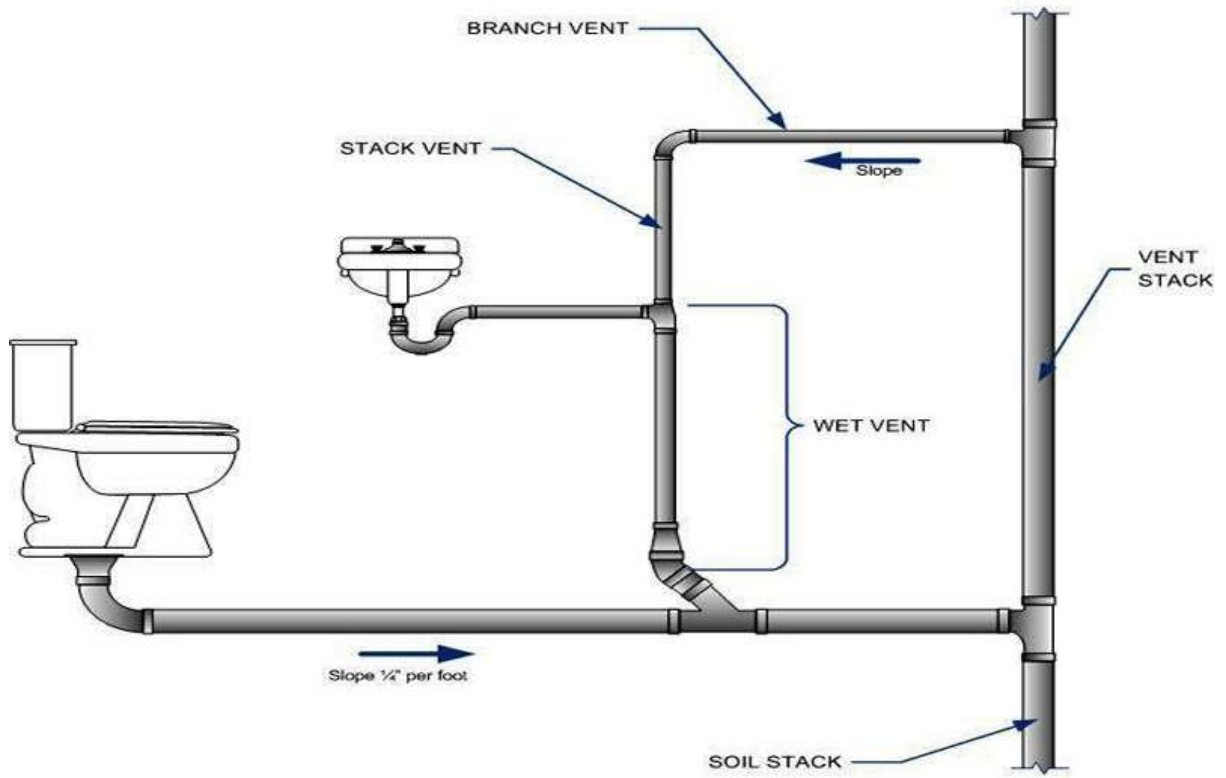

**Exercise 3: Water pump Installation**

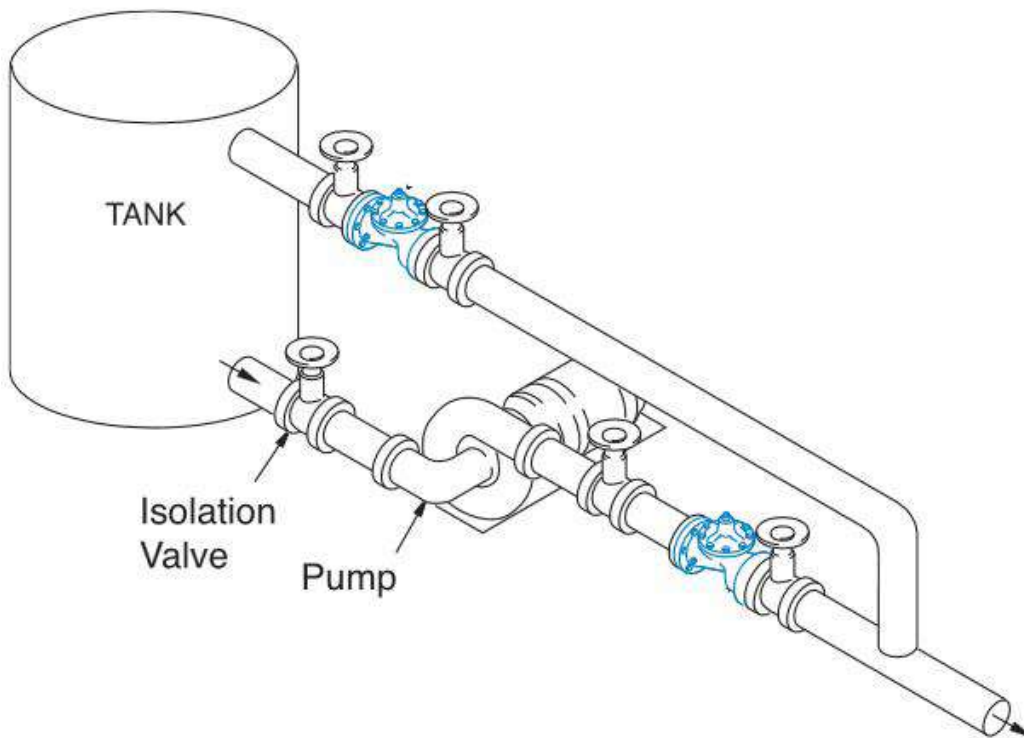
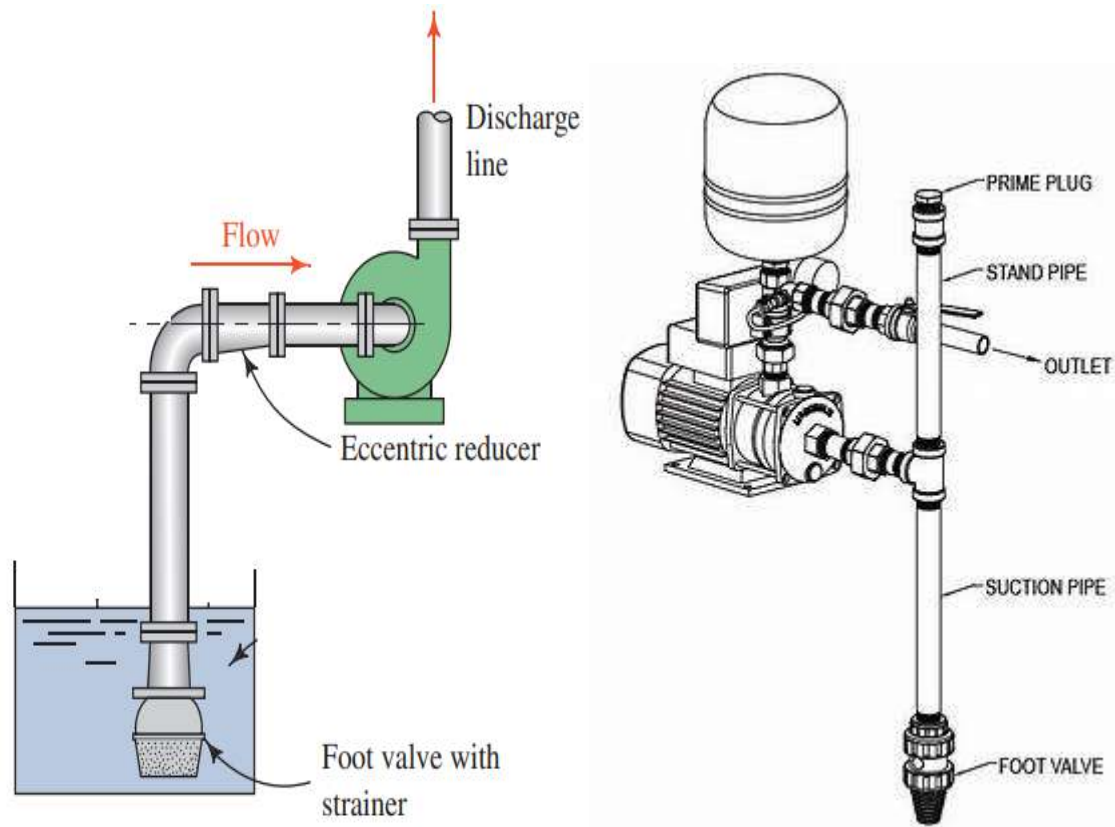

**Exercise 5: Electrical Power supply for domestic applications.**



